

# Showco

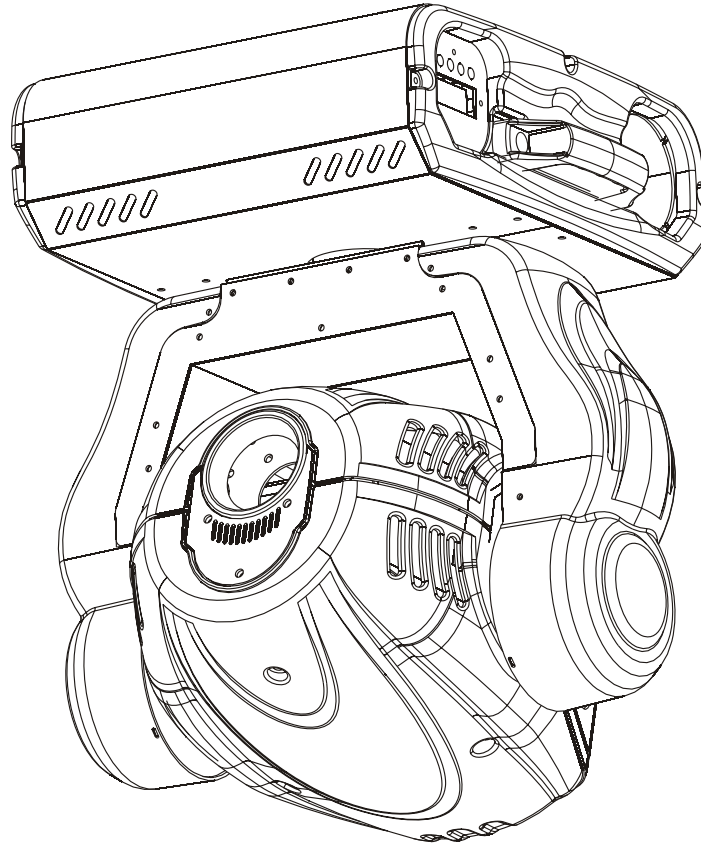

## Spot 250 v1

## ENGLISH INDEX

1) Open the box and checking	Page 1
2) Safety instructions	Page 1
3) Operating determinations	Page 2
4) Description of the device	Page 3
5) Installion	Page 4
6) Control Board Operation	Page 8
7) DMX512 Channel Function	Page 9
8) Technical specifications	Page 18
9) Beampath	Page 19
10) Maintenance and cleaning	Page 20
11) Structure of the fixture	Page 21
12) Electrical diagram	Page 22
13) Commen faulty maintain	Page 23
14) Component antitheses	Page 24
15) Main PCB	Page 26
16) Display PCB	Page 27
17) Driver(L) PCB	Page 28
18) Driver(S) PCB	Page 29

Please read over this manual before operation the light

---

## 1 Open the box and checking

Congratulations on choosing our products! Please carefully read this instruction manual in its entirety and keep it well for using reference. This manual contained about the installation and the relative using information of this products. Please according to this manual's relative speaking when using this equipment.

This equipment was made of new style, high intensity plastic. It fully shows the modern times light characteristic with beauty structure. And it was made according to CE standard. Fully up the international standard of DM X 512 agreement. Master or slave in phase control. Can be use in large entertainm ent, theater, perform ing and playing hall, etc.

This product uses M SD 250 or M SD 250/2 electrical arc lamp. When receiving this product please carefully bring and put; and check that whether this equipment has been damaged or not during transportation. And please also check the following thing was enclosed:

Signal line	—————	one piece	Safety string	—————	one piece
User Manual	—————	one set	Omega holder	—————	two pieces

## 2. Safety instructions

Every person involved with installation and maintenance of this device have to:

- be qualified
- follow the instructions of this manual

### CAUTION:

- Keep this device away from rain and moisture!
- Unplug mains lead before opening the housing!
- FOR YOUR OWN SAFETY, PLEASE READ THIS USER MANUAL CAREFULLY
- BEFORE YOU INITIAL START -UP!
- Be careful with your operations.
- With a high voltage you can suffer a dangerous electric shock when touching the wires!
- This device has left our premises in absolutely perfect condition. In order to maintain this condition and to ensure a safe operation, it is absolutely necessary for the user to follow the safety instructions and warning notes written in this manual.

### Important:

- The manufacturer will not accept liability for any resulting damages caused by the non-observance of this manual or any unauthorized modification to the device.
- Please consider that damages caused by manual modifications to the device are not subject to warranty.
- Never let the power-cord come into contact with other cables! Handle the power-cord and all connections with the mains with particular caution!
- Make sure that the available voltage is not higher than stated on the rear panel.
- Always plug in the power plug least. Make sure that the power-switch is set to OFF-position before you connect the device to the mains. The power-plug has to be accessible after installing the device.
- Make sure that the power-cord is never crimped or damaged by sharp edges. Check the device and the power cord from time to time.

- 
- by the plug. Never pull out the plug by tugging the power-cord.
  - This device falls under protection class I. Therefore it is essential to connect the yellow /green conductor to earth.
  - The electric connection, repairs and servicing must be carried out by a qualified employee.
  - Do not connect this device to a dimmer pack.
  - Do not switch the fixture on and off in short intervals as this would reduce the lamp's life.
  - During the initial start-up some smoke or smell may arise. This is a normal process and does not necessarily mean that the device is defective.
  - Do not touch the device's housing bare hands during its operation (housing becomes hot)!
  - For replacement use lamps and fuses of same type and rating only.

## CAUTION :

### EYE DAMAGES !

Avoid looking directly into the light source (mean especially for epileptics) !

## 3.0 operating determinations

- This device is a moving-head spot for creating decorative effects and was designed for indoor use only.
- If the device has been exposed to drastic temperature fluctuation (e.g. After transportation), do not switch it on immediately. The arising condensation water might damage your device. Leave the device switched off until it has reached room temperature.
- Never run the device without lamp!
- Do not shake the device. Avoid brute force when installing or operating the device.
- Never lift the fixture by holding it at the projector-head, as the mechanics may be damaged. Always hold the fixture at the transport handles.
- When choosing the installation-spot, please make sure that the device is not exposed to extreme heat, moisture or dust. There should not be any cables lying around. You endanger your own and the safety of others!
- The minimum distance between light-output and the illuminated surface must be more than 2 meters.
- Make sure that the area below the installation place is blocked when rigging, derigging or servicing the fixture. Always fix the fixture with an appropriate safety-rope. Fix the safety-rope at the correct holes only.
- Only operate the fixture after having checked that the housing is firmly closed and all screws are tightly fastened.
- The lamp must never be ignited if the objective-lens or any housing-cover is open, as discharge lamps may explode and emit a high ultraviolet radiation, which may cause burns.
- The maximum ambient temperature  $t_a = 45^{\circ}\text{C}$  must never be exceeded. Otherwise, the lamp is switched off and the fixture is out of operation for 5 minutes..

## 4 D description of the device

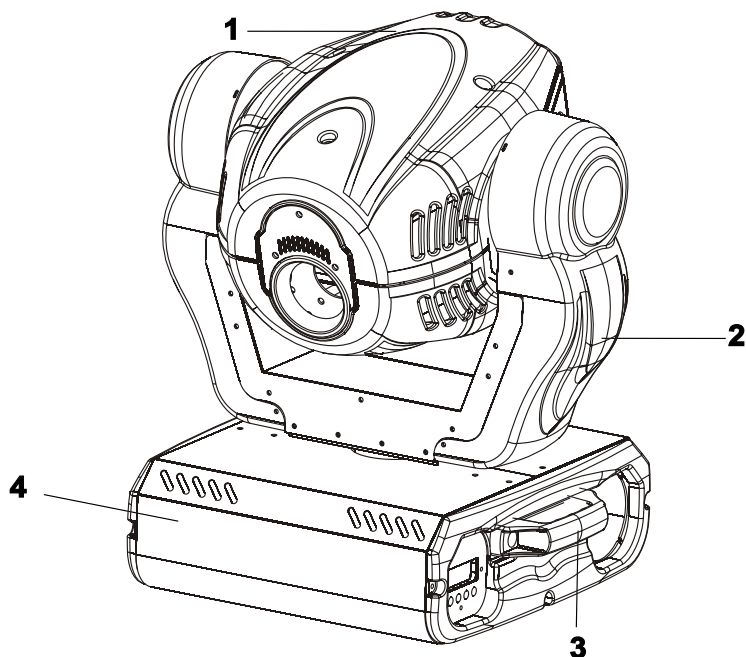

- 1 - Moving head
- 2 - Yoke
- 3 - Carry handles
- 4 - Base

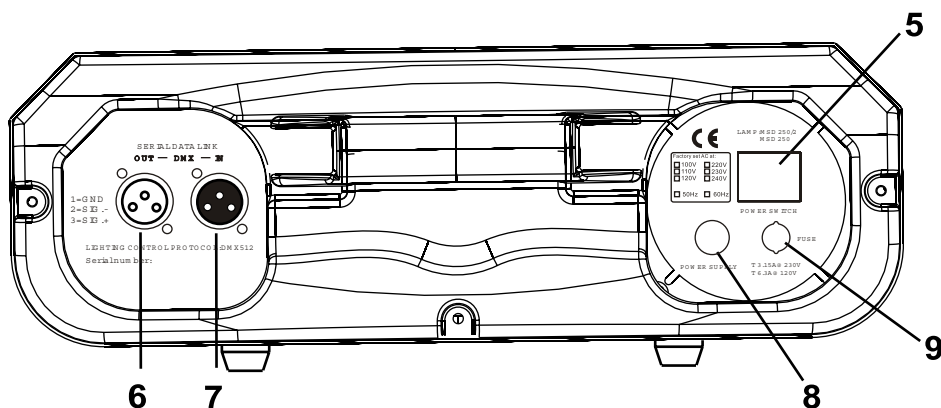

- 5 - Powerswitch
- 6 - DMX output
- 7 - DMX input
- 8 - Powercord
- 9 - Fuse holder

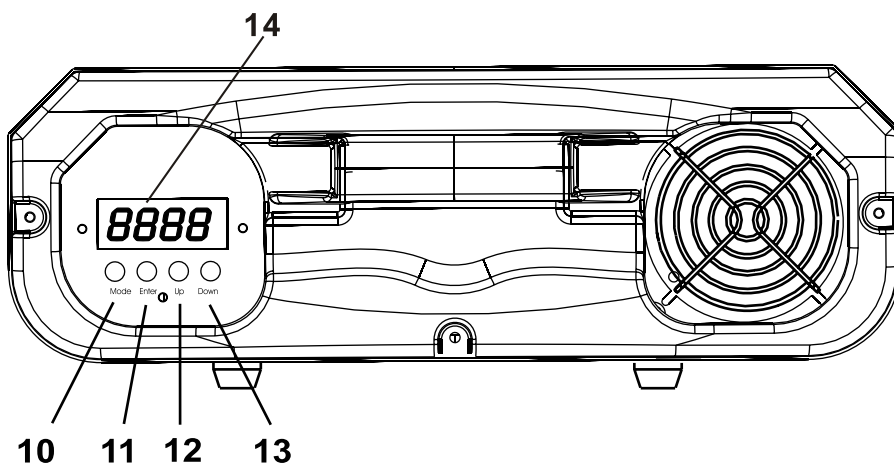

- 10 - Mode button
- 11 - Enter button
- 12 - Up button
- 13 - Down button
- 14 - Display

---

## 5 .Installation

### 5 .1 Fitting the lamp

To insert the lamp M SD 250 or M SD 250/2 open the top cover of the projector-head (see the drawing to identify which cover is top) by loosening the 3 screws on the cover. Then open the small lamp cover by loosening 2 fastening screws (see the drawing) . If changing the lamp, remove the old lamp from the socket. Insert the lamp to the socket. Do not install a lamp with a higher wattage! A lamp like this generates temperatures the device is not designed for. Damages caused by non-observance are not subject to warranty. Please follow the lamp manufacturer 's notes! Do not touch the glass bulb with bare hands during the installation! Make sure that the lamp is installed tightly into the lamp holder system . Adjust the optimal distance 1-1.5 mm from the lens by turning the screw "A " (see the drawings "Lamp adjustment" below ) on the rear panel of the head . Then close the small lamp cover by tighten 2 fastening screws again . Reclose the top cover of the head and tighten the 3 screws.

Lamp assembly:

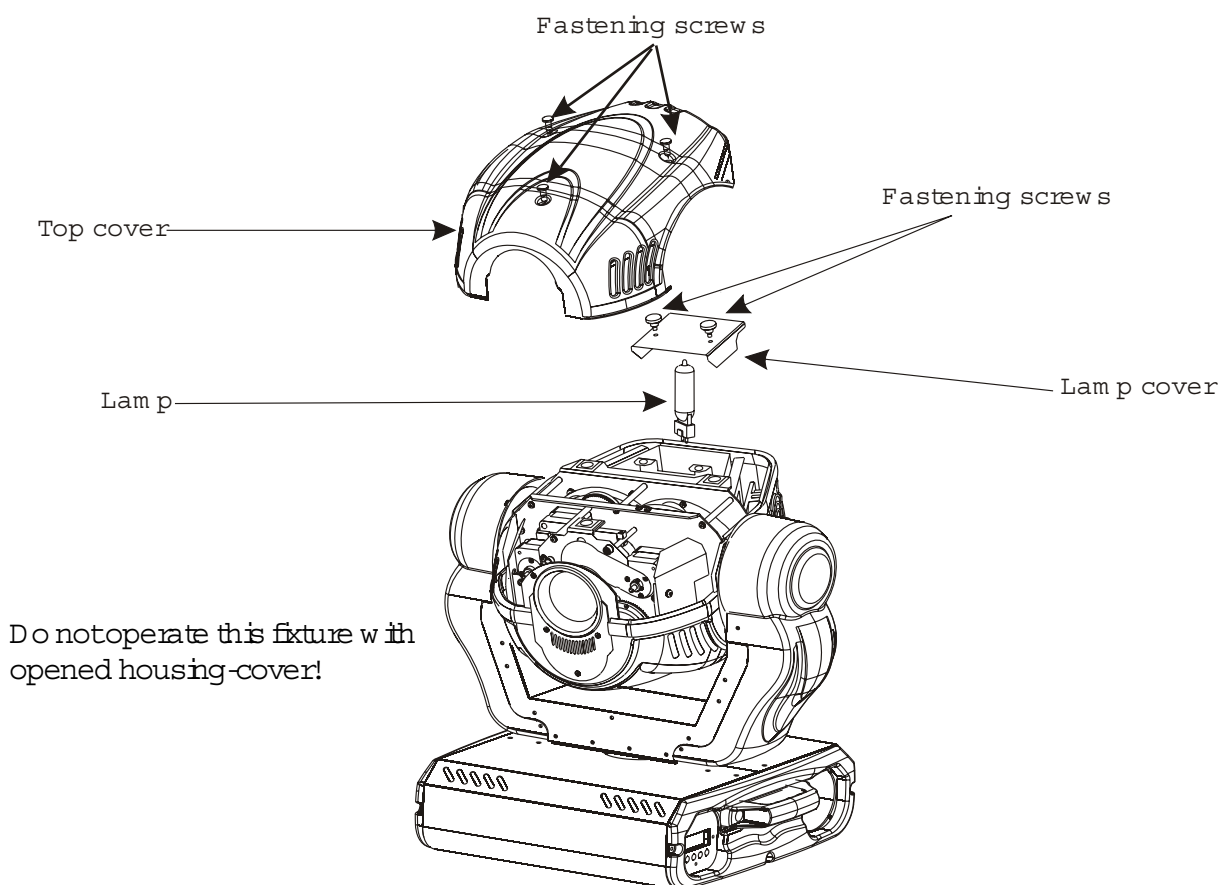

## 5.2 Lamp adjust

The lamp holder is aligned at the factory. Due to differences between lamps, fine adjustment may improve light performance. Strike the lamp, open the shutter and the iris, set the dimmer intensity onto 100% and focus the light on a flat surface (wall). As the optimum distance of the lamp from lens was adjusted during the installing or changing the lamp (by turning the screw "A"), it is necessary to adjust only the second position by turning the screw "B", in order to center the hot-spot (the brightest part of the beam). If the hot spot seems to be too bright, you can lower its intensity by moving the lamp close to the reflector. Do so by turning the screw "A" until the light is evenly distributed. If the light on the edge seems to be brighter as in the center, the lamp is too close at the reflector. In this case, you need to move the lamp away from the reflector until the light is evenly distributed and the beam appears bright enough.

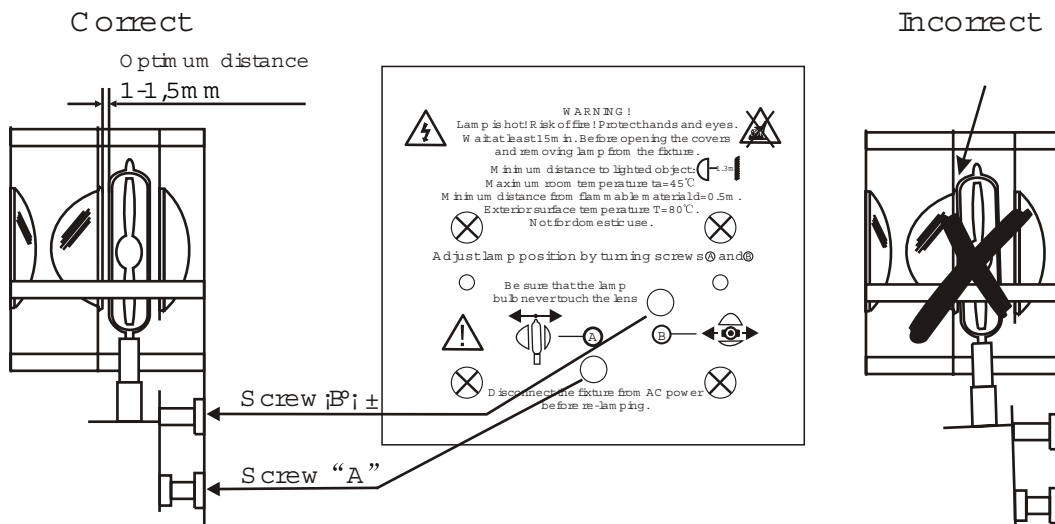

## 5.3 Inserting/Exchanging gobos

Turn off the lamp and allow it to cool for at least 10 minutes. Disconnect the fixture from power. To insert the gobos open the top cover of the moving-head by loosening the 3 screws on the top cover and follow the instructions below:

Rotating gobo-wheel:

Press the ends of the fixation-ring together with an appropriate tool and remove it.

Remove the gobo and insert the new gobo. Press the ends of the fixation-ring together and insert it in the front of the gobo.

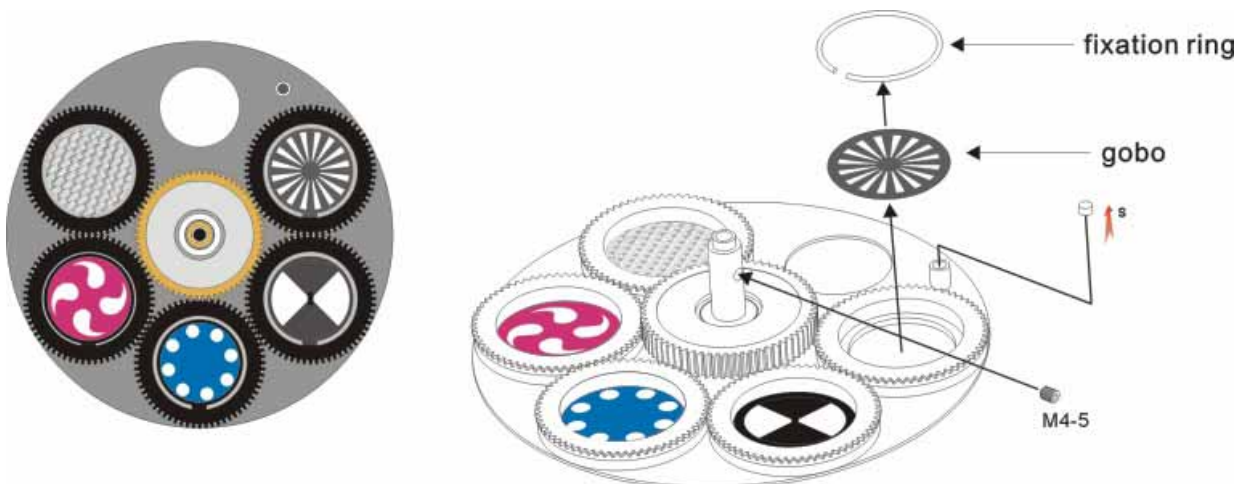

#### Colour/Static gobo-wheel:

Gently bend out the gobo holder to release it from the fixative holes and eject it from the pressing snap. Press the ends of the fixation-ring together with an appropriate tool and remove it. Remove the gobo and insert the new gobo. Press the ends of the fixation-ring together and insert it in the front of the gobo. Put the gobo holder back under the pressing snap and push it to the 3 fixative notches.

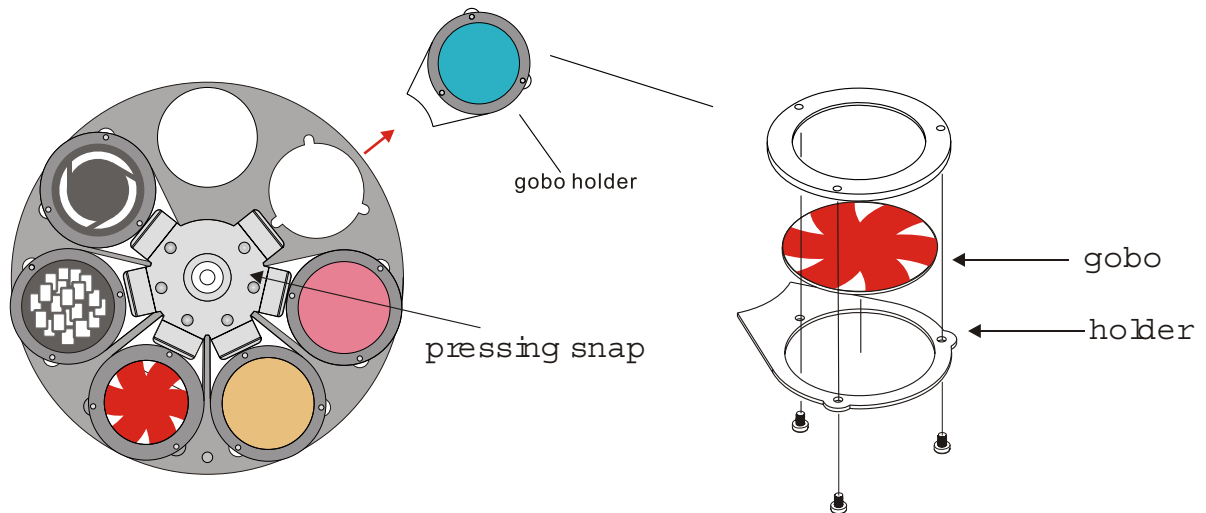

#### 5.4 Rigging the fixture

**DANGER TO LIFE!** Please consider the respective national norms during the installation! The installation must only be carried out by an authorized dealer!

- The installation of the projector has to be built and constructed in a way that it can hold 10 times the weight for 1 hour without any harmful deformation.
- The installation must always be secured with a secondary safety attachment, e.g. an appropriate catch net. This secondary safety attachment must be constructed in a way that no part of the installation can fall down if the main attachment fails.
- When rigging, derigging or servicing the fixture staying in the area below the installation place, on bridges, under high working places and other endangered areas is forbidden.
- The operator has to make sure that safety-relating and machine-technical installations are approved by an expert before taking into operation for the first time and after changes before taking into operation another time.
- The operator has to make sure that safety-relating and machine-technical installations are approved by an expert after every four years in the course of an acceptance test.
- The operator has to make sure that safety-relating and machine-technical installations are approved by a skilled person once a year.
- The projector should be installed outside areas where persons may walk by or be seated.
- **IMPORTANT! OVERHEAD RIGGING REQUIRES EXTENSIVE EXPERIENCE**, including (but not limited to) calculating working load limits, installation material being used, and periodic safety inspection of all installation material and the projector. If you lack these qualifications, do not attempt the installation yourself, but instead use a professional structural rigger. Improper installation can result in bodily injury and or damage to property.
- The projector has to be installed out of the reach of people.
- If the projector shall be lowered from the ceiling or high joists, professional trussing systems have to be used. The projector must never be fixed swinging freely in the room.
- **Caution:** Projectors may cause severe injuries when crashing down! If you have doubts concerning the safety of a possible installation, do NOT install the projector!
- Before rigging make sure that the installation area can hold a minimum point load of 10 times the projector weight.

- The projector can be placed directly on the stage floor or rigged in any orientation on a truss without altering its operation characteristics.
- For overhead use, always install a safety-rope that can hold at least 1.0 times the weight of the fixture. You must only use safety-ropes with screw-on carabines. Pull the safety-rope through the two apertures on the bottom of the base and over the trussing system etc. Insert the end in the carabine and tighten the fixation screw.

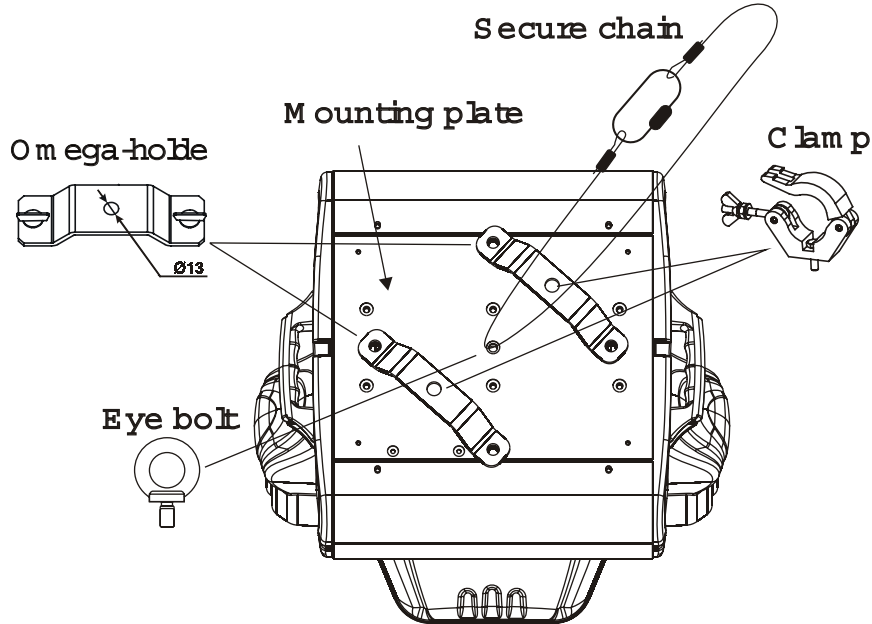

### 5.5 Connection to the mains

Verify the power supply settings before applying power!

If you wish to change the power supply settings, see the chapter Appendix.

Connect the fixture to the mains with the enclosed power cable and plug.

The earth has to be connected!

The occupation of the connection-cables is as follows:

Cable (EU)	Cable (US)	Pin	International
Brown	Black	Live	L
Lightblue	White	Neutral	N
Yellow/Green	Green	Earth	⊕

### 5.6 DMX-512 connection/connection between fixtures

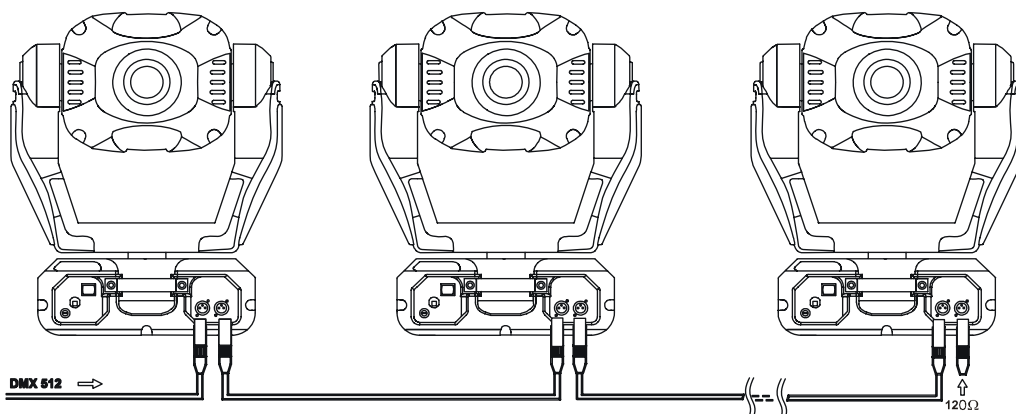

Only use a stereo shielded cable and 3-pin XLR-plugs and connectors in order to connect the controller with the fixture or one fixture with another.

Occupation of the XLR-connection :

DMX-OUTPUT  
XLR mounting-socket:

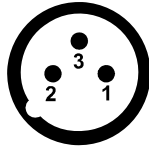

- 1 - G round
- 2 - Signal(-)
- 3 - Signal(+)

DMX-input  
XLR mounting-plug :

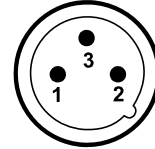

- 1 - G round
- 2 - Signal(-)
- 3 - Signal(+)

Caution : At the last fixture, the DMX-cable has to be terminated with a terminator. Solder a 120Ω resistor between Signal (-) and Signal (+) into a 3-pin XLR-plug and plug it in the DMX-output of the last fixture.

The transform of the controller line of 3 pins and 5 pins (plug and socket)

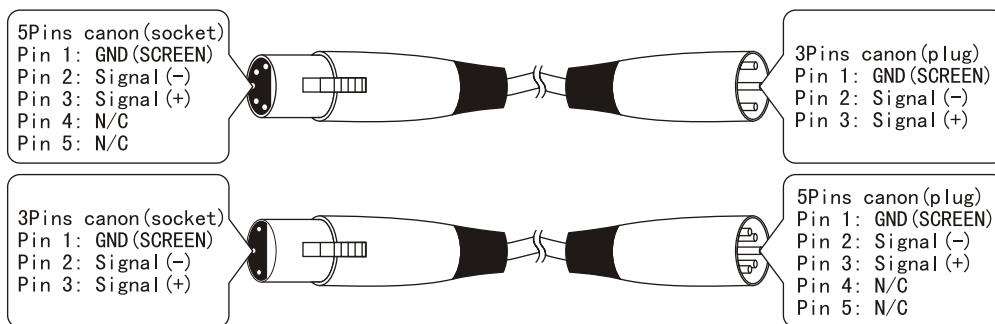

## 6. Control Board Operation

Function Table:

Mode	Function	Condition
<i>PAN</i>	Pan movement in positive or negative direction	YES --negative direction
<i>TILT</i>	Vertical movement in positive or negative direction	YES --negative direction
<i>Addr</i>	Address code set	
<i>RESET</i>	Reset	YES --reset
<i>COLI</i>	Rainbow color wheel change color linear or stepping	YES --linear
<i>FUN</i>	Working mode	<i>OFF</i> DMX 512 mode
		<i>PTG</i> Automatic
		<i>SLAE</i> Slave mode
<i>LAMP</i>	Lamp switch	<i>ON</i> Lamp on
		<i>OFF</i> Lamp off
<i>VER</i>	Software version	
<i>HEAT</i>	Lamp hot	
<i>LA.EF</i>	Lamp error	

Controlboard operation way:

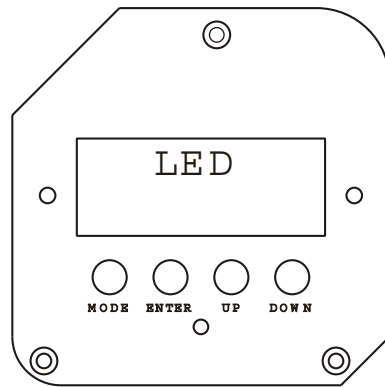

- 1 .Select working mode by pressing M O D E .
- 2 .Press ENTER to confirm the selection .
- 3 .Press UP and DOWN to select working condition .
- 4 .Press ENTER to confirm the selection .

### 7.DM X 512 Channel Function

CHANNEL	FUNCTION
1	PAN
2	TILT
3	PAN FINE (proportional)
4	TILT FINE (proportional)
5	Speed of PAN /TILT movement
6	Lamp on/off & reset
7	Colors 1
8	Static gobos/colors 2
9	Prism
10	3-facet Prism rotation
11	Rotating gobos
12	Rotating gobo index, rotating gobo rotation
13	Zoom , frost,UV filter
14	Focus (proportional)
15	Shutter/ strobe
16	Dimmer intensity (proportional)

## CHANNEL 1 : PAN

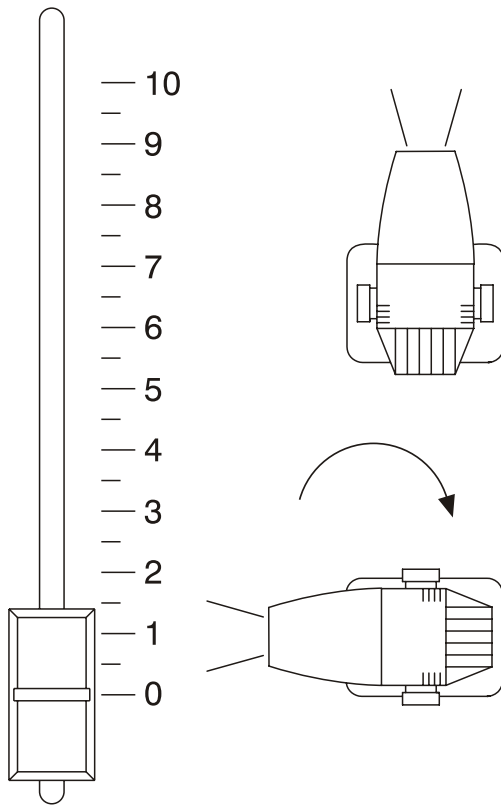

Value	%	E ffect
255	100	C lockw ise 530° rotate
0	0	

## CHANNEL 2 : TILT

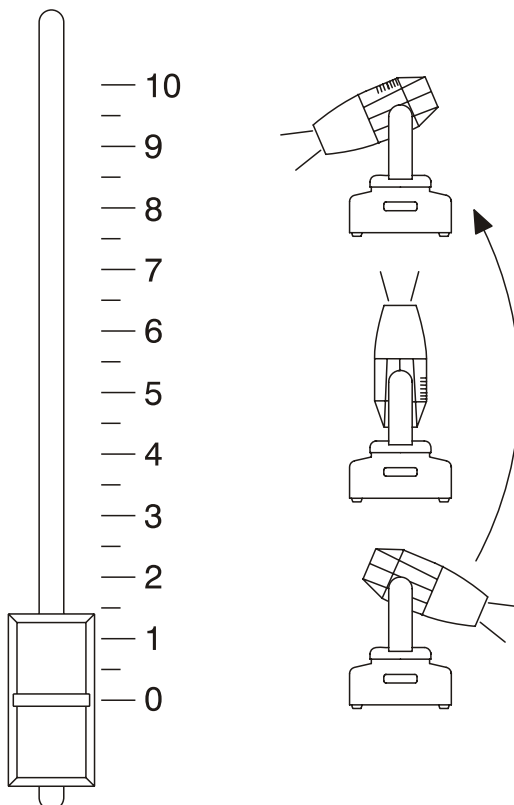

Value	%	E ffect
255	100	Anti-clockw ise 280° rotate
0	0	

### CHANNEL 3: PAN FINE (proportional)

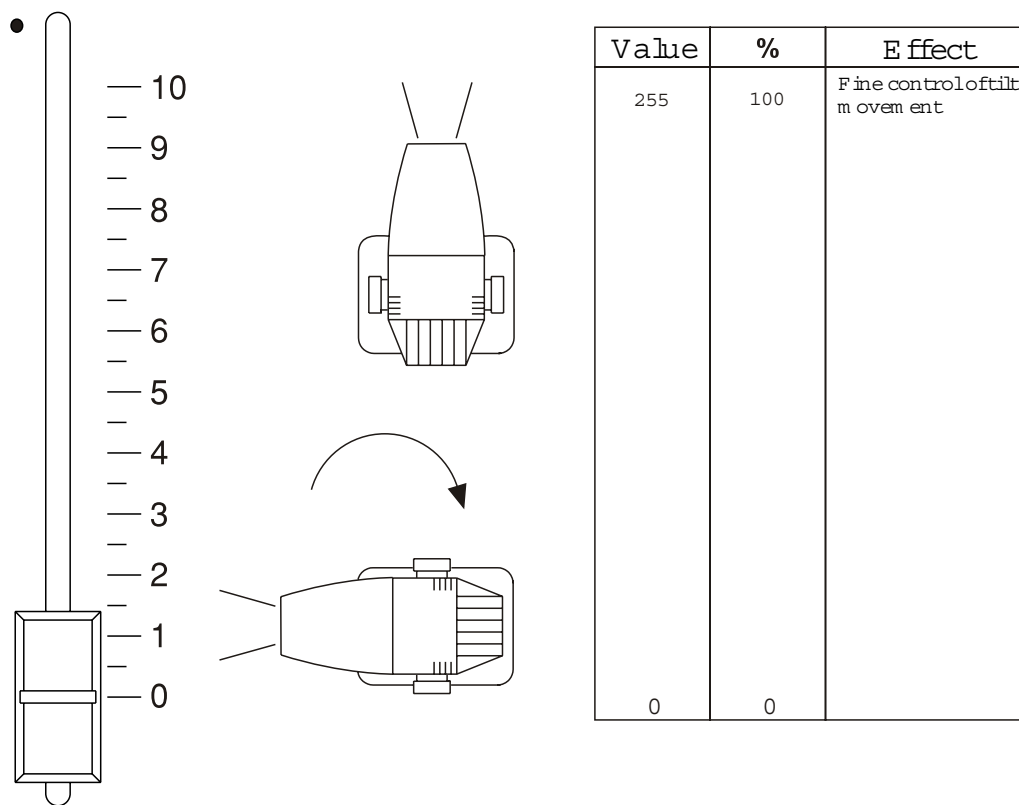

### CHANNEL 4: TILT FINE (proportional)

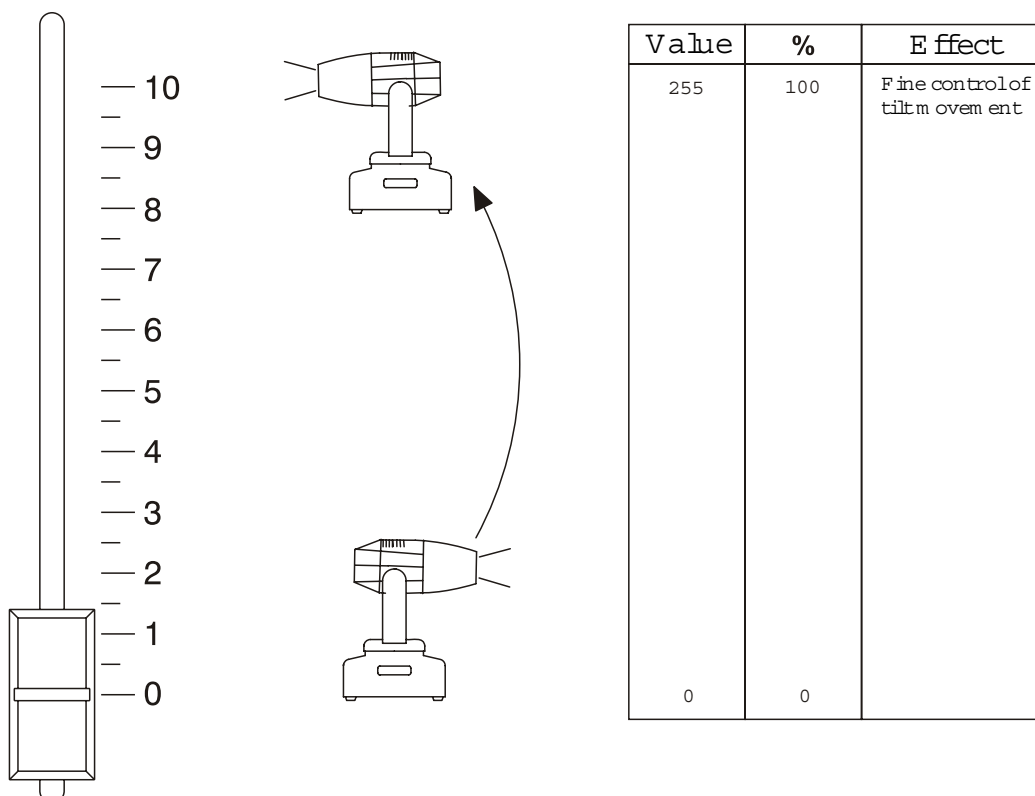

## CHANNEL 5 : Speed of PAN /TILT movement

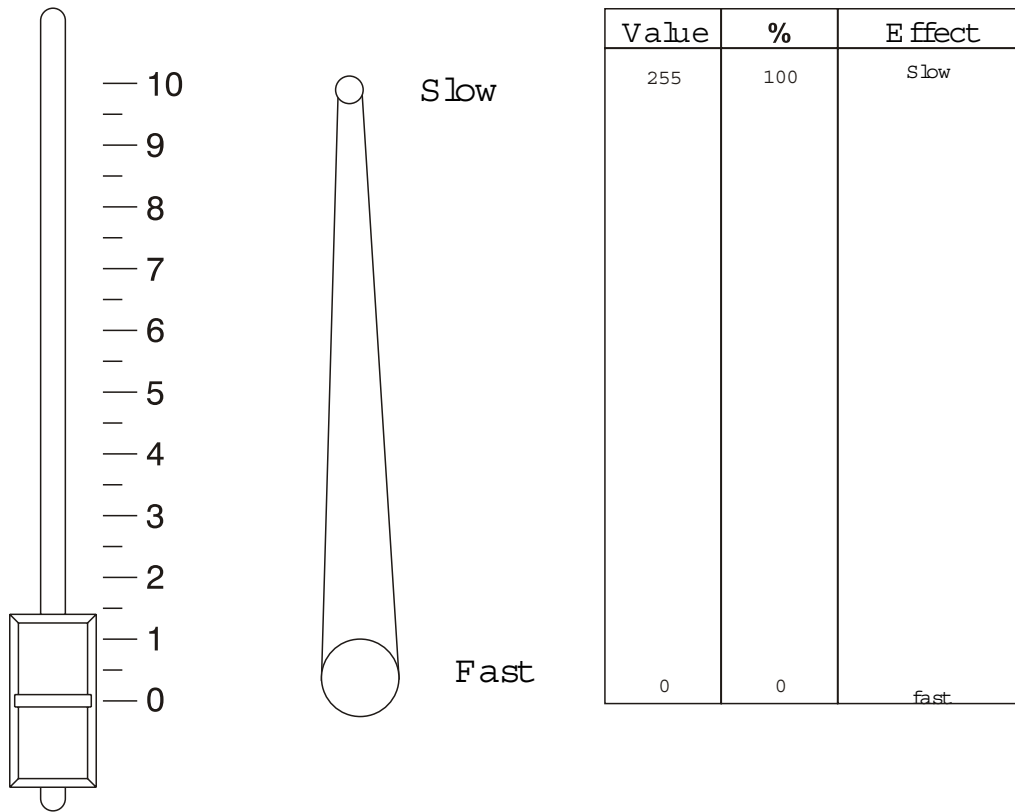

## CHANNEL 6 : Lamp on/off & reset

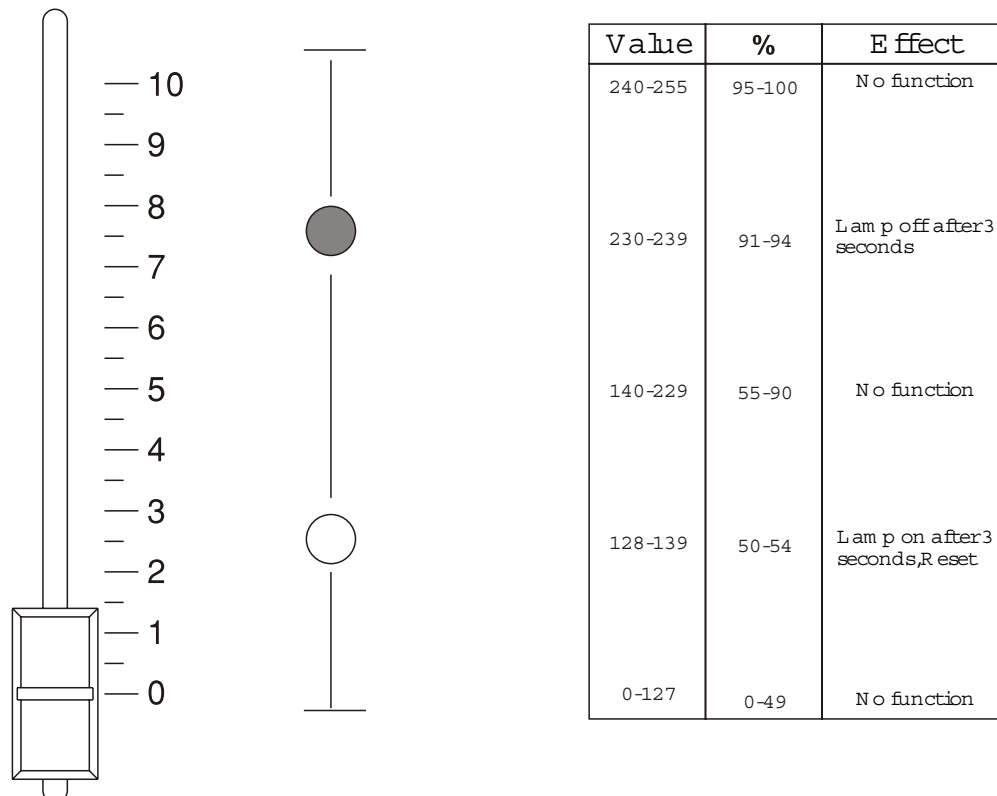

## CHANNEL 7: Color1

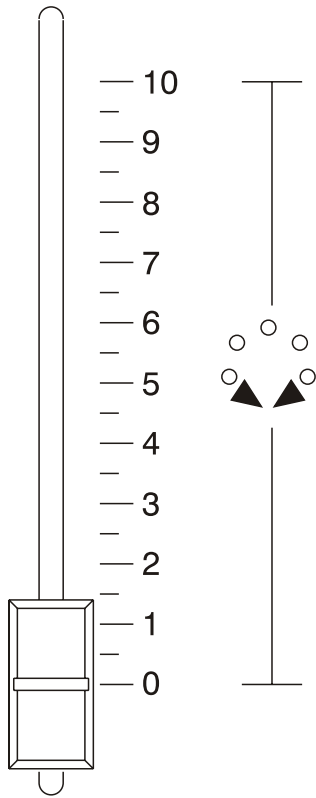

Value	%	Effect
128-255	50-100	Forwards rainbow effect from slow to fast
112-127	44-49	Pink
96-111	37-43	Blue
80-95	31-36	Orange
64-79	25-30	Green
48-63	19-24	Magenta
32-47	12-18	Yellow
16-31	6-11	Red
0-15	0-5	Open/white

## CHANNEL 8: Staticgobo /color2

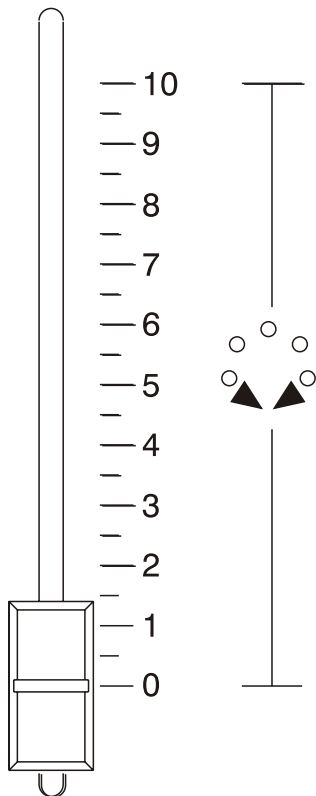

Value	%	Effect
222-255	87-100	Light Blue
185-221	72-86	Pale purple
148-184	57-71	Light Orange
111-147	43-56	Static gobo 3
74-110	28-42	Static gobo 2
37-73	14-27	Static gobo 1
0-36	0-13	White

## CHANNEL 9: Prism

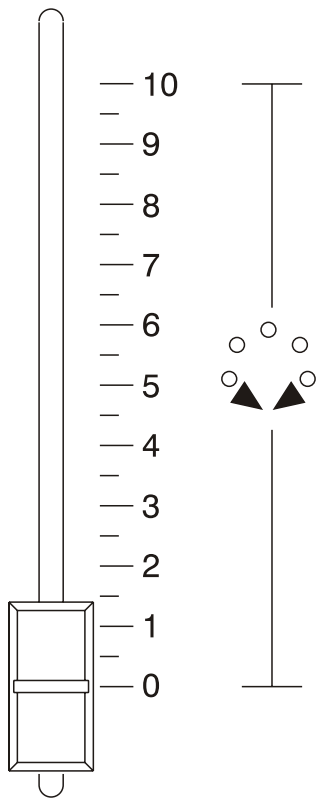

Value	%	Effect
128-255	100	3-facet prism
0-127	0	No function

## CHANNEL 10: 3-facet prism rotation

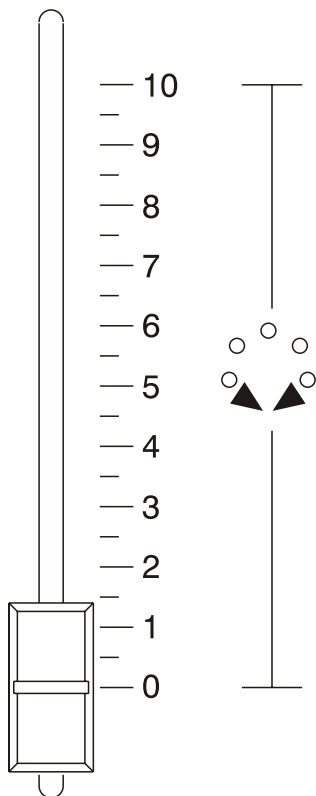

Value	%	Effect
133-255	53-100	Backwards rotation from slow to fast
128-132	51-52	No rotation
5-127	3-50	Forwards rotation from fast to slow
0-4	0-2	No rotation

## CHANNEL 11: Rotating gobos

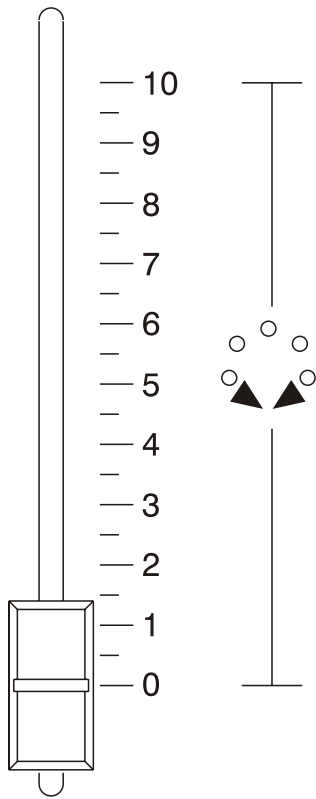

Value	%	Effect
224-255	88-100	Rotate gobo wheel continue rotation from slow to fast
160-223	63-87	Rotate gobo 5
128-159	50-62	Rotate gobo 4
96-127	37-49	Rotate gobo 3
64-95	25-36	Rotate gobo 2
32-63	12-24	Rotate gobo 1
0-31	0-11	Open/hole

## CHANNEL 12: Rotating gobo index, rotating gobo rotation

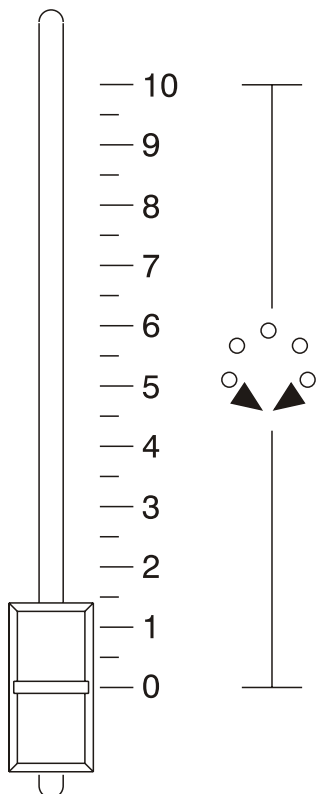

Value	%	Effect
159-255	62-100	Backwards gobo rotation from slow to fast
61-158	24-61	Forwards gobo rotation from slow to fast
0-60	0-23	Gobo indexing (0-540°)

## CHANNEL 13 : Zoom ,frost,UV filter

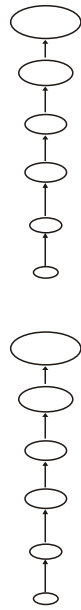
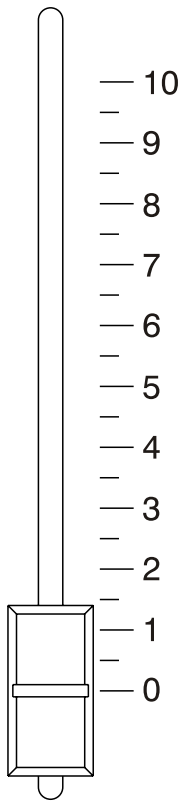

Value	%	Effect
240-255	93-100	UV-filter
224-239	87-92	Frost
208-223	82-86	Zoom 26°
192-207	75-81	Zoom 24°
176-191	68-74	Zoom 21°
160-175	62-67	Zoom 18°
128-159	50-61	Zoom 15°
112-127	43-49	UV-filter
96-111	37-42	Frost
80-95	31-36	Zoom 26°
64-79	24-30	Zoom 24°
48-63	18-23	Zoom 21°
32-47	12-17	Zoom 18°
0-31	0-11	Zoom 15°

Zoom without focus correction  
 Zoom without focus correction

## CHANNEL 14 : Focus (proportional)

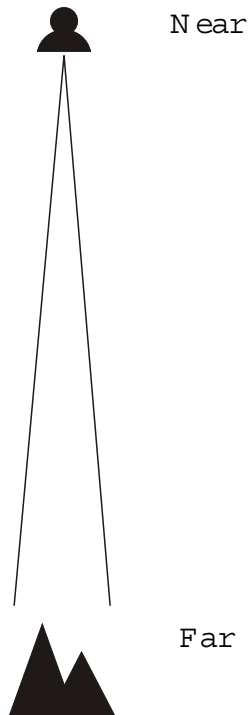
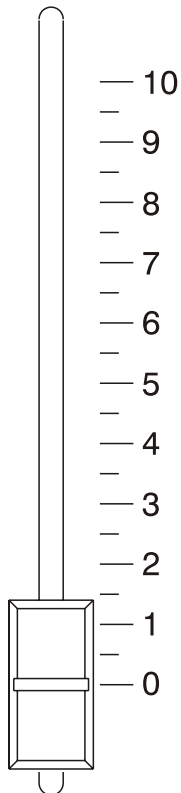

Value	%	Effect
255	100	close distance
0	0	far distance

## CHANNEL 15 : Shutter, strobe

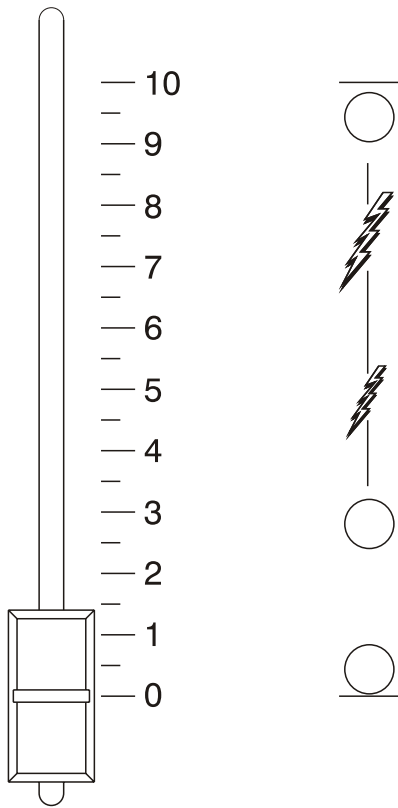

Value	%	Effect
224-255	87-100	Shutter Open
192-223	75-86	Random strobe-effect from slow to fast
160-191	62-74	Shutter Open
128-159	50-61	Pulse-effect in sequences from slow to fast
96-127	37-49	Shutter Open
64-95	25-36	Strobe-effect from slow to fast (max 10 Flashes/s)
32-63	12-24	Shutter Open
0-31	0-11	Shutter closed

## CHANNEL 16 : Dimension intensity (proportional)

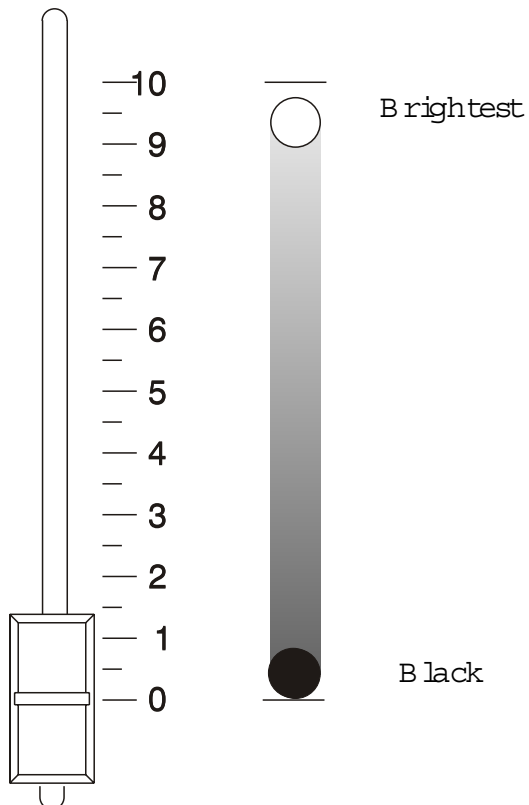

Value	%	Effect
255	100	Brightest
0	0	Black

---

## 8. Technical specifications

US model: Voltage.....AC 100/110/120V , 50/60Hz  
Fuse.....T 6.3A @ 120V  
EU model: Voltage.....AC 220/230/240V , 50/60Hz  
Fuse .....T3.15A @ 230V

Rated Power: 350W

DMX512 Channel: 16CHS

Luminous: 18000 LM

Lamp: Philips MSD 250/2 or MSD 250 GY 9,5

### Optical System :

- Focus: Linear electric focus
- Zoom : Motorized multi-step-zoom with five different apertures (15° , 18° , 21° , 24° , 26° )

### Color:

- 7 dichroic-filters plus white, colour-wheel with variable rotation speed in both directions

Strobe: Variable speed (1-10 flashes/sec)

### Rigging:

- Stands directly on the floor
- Mounts horizontally or vertically with 2 clamps
- 1 truss orientation
- Safety chain/cord attachment bolt

### Temperatures

- Maximum ambient temperature  $t_a$ : 45°C
- Maximum housing temperature  $t_b$  (steady state): 80°C

### Minimum distances:

- Minimum distance from flammable surfaces: 0.5m
- Minimum distance to lighted object: 2.0m

Dimmer: Smooth dimmer 0-100%

### Pan /Tilt Movement:

- Pan 530° , Tilt 280°
- Micro-step scan effect
- Auto-repositioning by photoelectric repositioning system
- Linearity move speed adjust.

Prisms: 3-facet prism (dual direction rotation with adjustable speed)

### Dimensions and weight:

- Length of base (including handles): 400 mm
- Width of yoke: 400 mm
- Height (head horizontal): 476 mm
- Weight (net): 26 kg

## 9. Beam path

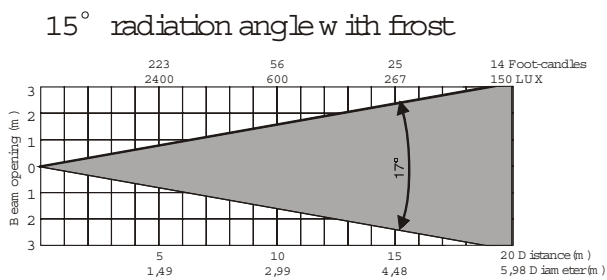
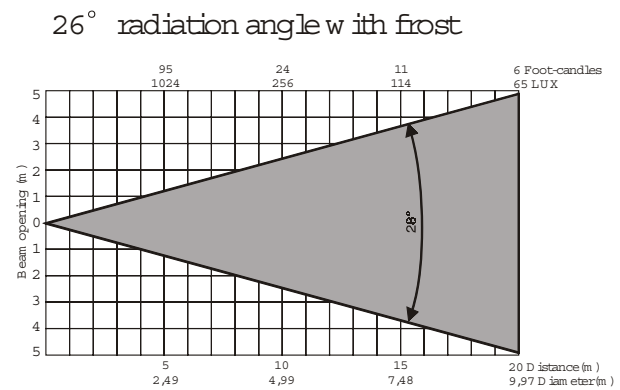
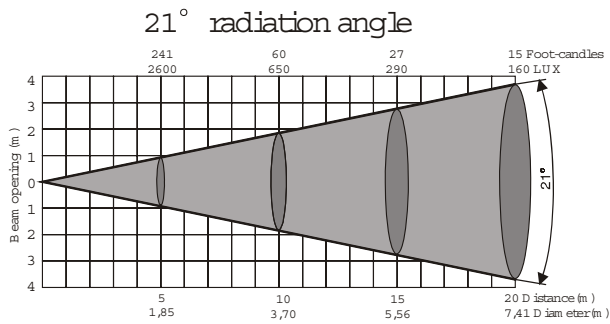
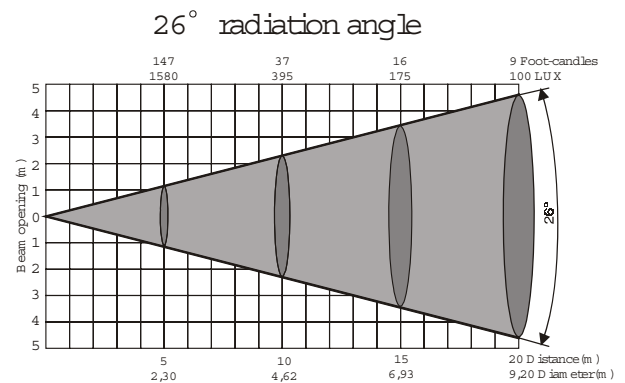
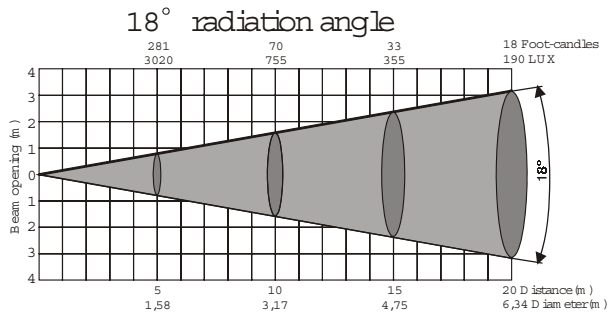
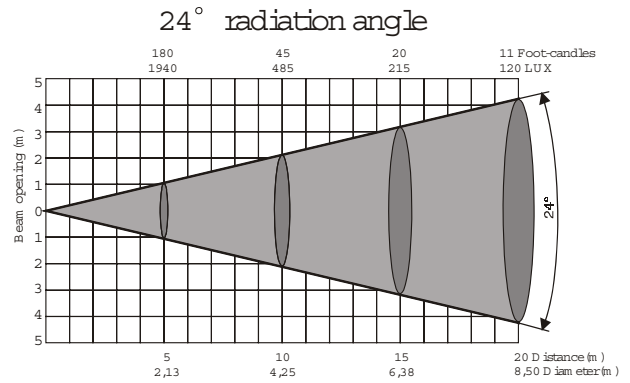
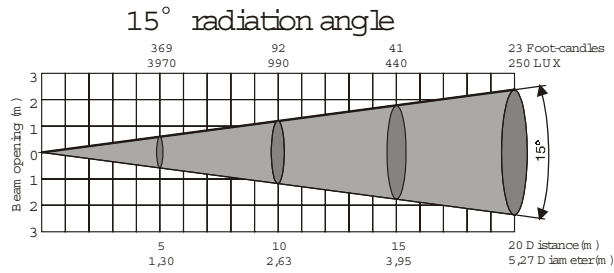

---

## 10. Maintenance and cleaning

It is absolutely essential that the fixture is kept clean and that dust, dirt and smoke-fluid residues must not build up on or within the fixture. Otherwise, the fixture's light-output will be significantly reduced. Regular cleaning will not only ensure the maximum light-output, but will also allow the fixture to function reliably throughout its life. A soft lint-free cloth moistened with any good glass cleaning fluid is recommended, under no circumstances should alcohol or solvents be used!

**DANGER:** Disconnect from the mains before starting any maintenance work

The front objective lens will require weekly cleaning as smoke-fluid tends to build up residues, reducing the light-output very quickly. The cooling-fans should be cleaned monthly.

The gobo may be cleaned with a soft brush. The interior of the fixture should be cleaned at least annually using a vacuum-cleaner or an air-jet.

The dichroic colour-filters, the gobo-wheel and the internal lenses should be cleaned monthly.

To ensure a proper function of the gobo-wheel, we recommend lubrication in six month intervals. The quantity of oil must not be excessive in order to avoid that oil runs out when the gobo-wheel rotates.

There are no serviceable parts inside the device except for the lamp and the fuse. Please refer to the instructions under "Fitting/Exchanging the lamp" Maintenance and service operations are only to be carried out by authorized dealers.

Replacing the fuse

If the lamp burns out, the fine-wire fuse of the device might fuse, too. Only replace the fuse by a fuse of same type and rating. Before replacing the fuse, unplugging mains lead.

Procedure:

- 1) Unscrew the fuseholder on the rear panel of the base with a fitting screw driver from the housing (anti-clockwise).
- 2) Remove the old fuse from the fuseholder.
- 3) Install the new fuse in the fuseholder.
- 4) Replace the fuseholder in the housing and fix it.