

Wizard Extreme

user manual



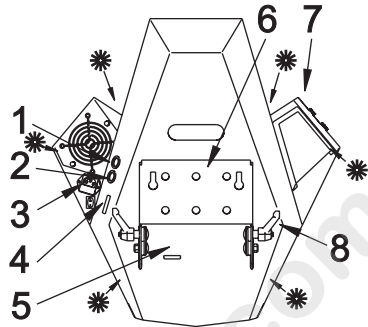

Martin

1. Data sockets
2. Power and Data LEDs
3. Power input, main fuse, power on/off switch
4. DIP switch
5. Safety cable eye
6. Mounting bracket
7. Lamp housing
8. Swivel locks
9. Focus rod (see illustration below right)

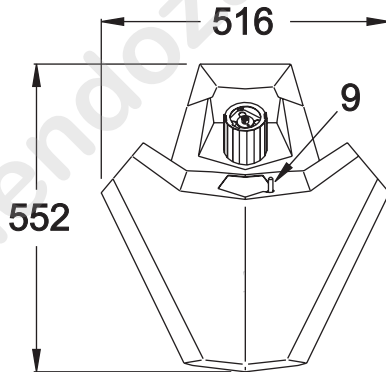
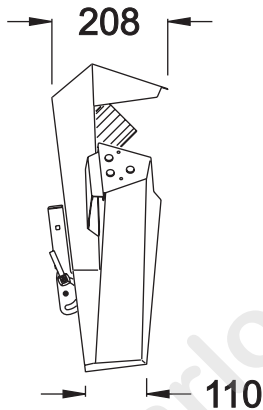

* Cover access screws



Measurements are in millimeters

© 2004-2007 Martin Professional A/S, Denmark.

All rights reserved. No part of this manual may be reproduced, in any form or by any means, without permission in writing from Martin Professional A/S, Denmark. Information subject to change without notice. Martin Professional A/S and all affiliated companies disclaim liability for any injury, damage, direct or indirect loss, consequential or economic loss or any other loss occasioned by the use of, inability to use or reliance on the information contained in this manual.

P/N 35000155, Rev. F

Introduction	5
Safety information	5
Unpacking	7
AC power	8
Installing a plug on the mains lead	8
Adjusting voltage settings	8
Installation	11
Wall mounting	11
Overhead mounting	12
Operation from the floor	12
Multi-coupler bracket	14
Data connection	15
Recommended cable	15
Connections	15
Stand-alone operation	17
Single-unit operation	17
Master / slave operation	17
Stand-alone settings	19
MC-1 operation	20
MC-1 settings	20
DMX operation	21
DMX modes	21
Setting the DMX mode	24
DMX control address	24
Basic service	26
Cleaning	26
Lamp maintenance	29
Fuses	31
Setting Wizard emulation and 1-channel modes	32
Updating firmware	32
Troubleshooting	34
DMX protocol: 11-channel mode	35
DMX protocol: Wizard emulation 8-channel mode	38
DMX protocol: 1-channel mode	40
Wizard Extreme specifications	41



Disposing of this product

Martin[®] products are supplied in compliance with Directive 2002/96/EC of the European Parliament and of the Council of the European Union on WEEE (Waste Electrical and Electronic Equipment), as amended by Directive 2003/108/EC, where applicable.

Help preserve the environment! Ensure that this product is recycled at the end of its life. Your supplier can give details of local arrangements for the disposal of Martin[®] products.

INTRODUCTION

Thank you for selecting the Martin Wizard Extreme. The Wizard Extreme is an automated lighting fixture that features:

- 12 factory-designed macros that allow light shows to be created quickly with minimal programming
- Strobe effects
- Two independent color/gobo wheels
- Seven solid colors, eight-split colors, and two white positions
- 13 gobos plus open position
- A rotating mirror dish
- A rotating mirror drum with variable swivel angle
- Adjustable focus with rapid adjustment mechanism
- Mechanical shutter
- Multiple control options that enable a broad range of effects

The combination of mirror dish and mirror drum delivers over 80 individual light beams. A new glass reflector design offers enhanced light output.

SAFETY INFORMATION

Warning! This product is not for household use. It presents risks of lethal or severe injury due to fire and heat, electric shock, and falls.

Read this manual before powering or installing the fixture, follow the safety precautions listed below and observe all warnings in this manual and printed on the fixture. If you have questions about how to operate the fixture safely, please contact a Martin distributor for assistance. Refer any service operation not described in this manual to a qualified technician. Do not modify the fixture or install other than genuine Martin accessories and upgrade kits.

Avoiding electric shocks

- Disconnect the fixture from AC power before removing or installing the lamp, fuses, or any part, and when not in use.
- Always ground (earth) the fixture electrically.

- Use only a source of AC power that complies with local building and electrical codes and has both overload and ground-fault protection.
- Do not expose the fixture to rain or moisture.
- Refer all service to a qualified technician.
- Never operate the fixture with missing or damaged lenses and/or covers.

Protecting yourself and others from burns and fire

- Never attempt to bypass the thermostatic switch or fuses. Always replace defective fuses with ones of the specified type and rating.
- Ensure that the air flow through fans and vents is free and unobstructed.
- Keep all combustible materials (for example fabric, wood, paper) at least 0.3 meters (12 inches) away from the fixture. Keep flammable materials well away from the fixture.
- Do not illuminate surfaces within 0.1 meters (4 inches) of the fixture.
- Provide a minimum clearance of 0.1 meters (4 inches) around fans and air vents.
- Replace the lamp if it becomes defective or worn out, or before usage exceeds the maximum service life. When replacing the lamp, allow the fixture to cool for at least 5 minutes before opening the fixture or removing the lamp. Protect your hands and eyes with gloves and safety glasses. It can take up to 15 minutes for the fixture to cool completely.
- Never place filters or other materials over the lens or mirror drum.
- The exterior of the fixture can reach temperatures up to 60° C (140° F) and the screws on the lamp plate can reach up to 90° C (194° F). Allow the fixture to cool for at least 5 minutes before handling.
- Do not operate the fixture if the ambient temperature (T_a) exceeds 40° C (104° F).
- Do not stare directly into the light.
- Never operate the fixture without all lenses and covers installed: an unshielded lamp can explode without warning and emits dangerous UV radiation that can cause burns and eye damage.
- Covers, shields, lenses or ultraviolet screens must be changed if they have become visibly damaged.
- The lamp must be changed if it has become damaged or thermally deformed.

Preventing injuries due to falls

- When suspending the fixture above ground level, verify that the structure can hold at least 10 times the weight of all installed devices.

- Verify that all external covers and rigging hardware are securely fastened and use an approved means of secondary attachment such as a safety cable.
- Block access below the work area whenever installing or removing the fixture.

UNPACKING

The packing material is carefully designed to protect the fixture during shipment – always use it to transport the fixture.

The Wizard Extreme is supplied with the following:

- 3-wire power cable.
- This user manual. The latest version of this manual is also available in the support area of the Martin website at <http://www.martin.com>

AC POWER

The Wizard Extreme's operating voltage is printed on the serial number label that can be found on the back of the Wizard Extreme. Verify that the operating voltage closely matches the AC supply voltage before applying power. Contact your Martin dealer if the operating voltage differs from your supply voltage by more than five percent.

INSTALLING A PLUG ON THE MAINS LEAD

The fixture's mains lead may require a grounding-type cord cap that fits your power distribution cable or outlet. Consult a qualified electrician if you have any doubts about proper installation.

Warning! *For protection from dangerous electric shock, the fixture must be grounded (earthed). The AC mains supply shall have overload and ground-fault protection.*

Important! *Verify that the feed cables are undamaged and rated for the current requirements of all connected devices before use.*

Following the cord cap manufacturer's instructions, connect the yellow and green wire to ground (earth), the brown wire to live, and the blue wire to neutral. The table below shows some pin identification schemes.

Wire	Pin	Marking	Screw color
brown	live	"L"	yellow or brass
blue	neutral	"N"	silver
yellow/green	ground		green

ADJUSTING VOLTAGE SETTINGS

EU Model

1. Disconnect the fixture from AC power.

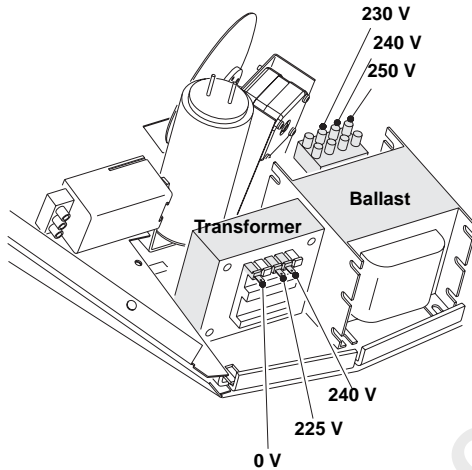

Local AC Supply		Transformer		Ballast
Freq.	Voltage	Setting	Terminal	Setting / Terminal
50 Hz	220 - 235 V	225 V	3	230 V
50 Hz	235 - 245 V	240 V	4	240 V
50 Hz	245 - 260 V	240 V	4	250 V

2. If the lamp is hot, allow it to cool for 5 minutes and wear safety goggles to protect your eyes.
3. Remove the six cover-access screws (see diagram inside the cover of this manual) and lift off the fixture cover.
4. On the *transformer*, move the BROWN wire to the transformer terminal shown in the table above for the local AC supply voltage. The terminals are indicated on a label on the top of the transformer.
5. On the *ballast*, move the BROWN wire to the terminal listed for the voltage. The terminals are indicated on the top of the ballast.
6. Replace the cover.

US model

Local AC Voltage	Transformer taps
95 - 110 V	Blue wire: 20V Brown wire: 120 V
110 - 130 V	Blue wire: 0 V Brown wire: 120 V
200 - 220 V	Blue wire: 20 V Brown wire: 230 V
220 - 240 V	Blue wire: 0 V Brown wire: 230 V
240 - 260 V	Blue wire: 0 V Brown wire: 250 V

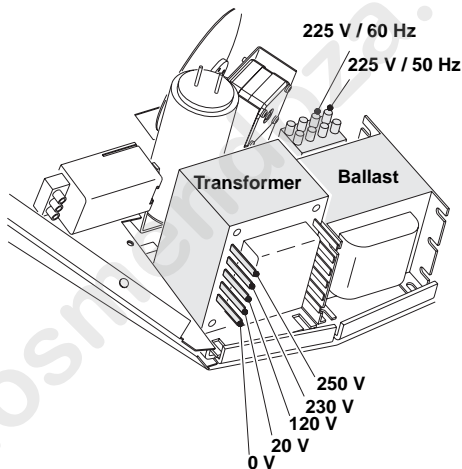

1. Disconnect the fixture from AC power.
2. If the lamp is hot, allow it to cool for 5 minutes and wear safety goggles to protect your eyes.
3. Remove the six cover-access screws (see diagram inside the cover of this manual) and lift off the fixture cover.
4. On the *ballast*, move the BLACK wire to the 225 V / 50 Hz terminal if you have 50 Hz local AC power, or to the 225 V / 60 Hz terminal if you have 60 Hz local AC power.
5. On the *transformer*, move the BLUE and BROWN wires to the taps listed in the table above for your local AC voltage. Taps are identified by a label on the top of the transformer.
6. Replace the cover.

INSTALLATION

The Wizard Extreme can be hung overhead with a clamp (not included), mounted vertically on a wall, or placed on the floor (using the optional floor stand).

Warning! *Block access below the work area before proceeding. Always use a secure means of secondary attachment.*

WALL MOUNTING

To mount the Wizard Extreme on a wall, or other vertical surface:

1. Verify that the surface is capable of bearing the weight of the fixture.
2. Set two 8mm-diameter hex bolts or screws, 155 mm (6.1 in.) apart (center to center), in the mounting surface.
3. Set an eyebolt in the mounting surface for the safety cable.
4. Fold the mounting bracket so that it lies flat against the back of the fixture and tighten the swivel locks. We recommend that you remove the swivel locks and replace them with M8 hexagonal lock nuts (these can be supplied by your Martin dealer: 2 x P/N 08132701); alternatively set the swivel locks so that they lie flat against the fixture.
5. Hang the fixture on the wall over the two screw/bolt heads using the two slotted holes in the mounting bracket.
6. Install a safety cable that can hold at least 10 times the weight of the fixture through the safety cable eye on the fixture and attach this to the eyebolt.
7. Verify that the fixture is at least 0.1 meters (4 in.) from the surface to be illuminated and at least 0.3 meters (12 in.) from any combustible materials. Verify that the clearance around the air vents is at least 0.1 meters (4 in.).

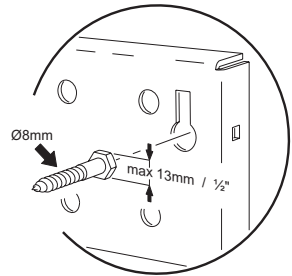

OVERHEAD MOUNTING

To hang the Wizard Extreme on an overhead support:

1. Verify that the structure can support at least 10 times the weight of all installed fixtures, clamps, cables, auxiliary equipment, and other items.
2. If hanging the fixture with a rigging clamp, verify that the clamp is undamaged and is designed for the fixture's weight. Bolt the clamp securely to the bracket with a grade 8.8 (minimum) M12 bolt and lock nut, or as recommended by the clamp manufacturer, through the clamp hole in the mounting bracket.
3. If permanently installing the fixture, verify that the hardware (not included) and mounting surface can bear at least 10 times the fixture's weight. Any of the six 13mm (½ in.) holes in the mounting bracket may be used for attachment, but ensure that the load is distributed evenly.
4. Working from a stable platform, clamp or fasten the fixture to the structure.
5. Install a safety cable that can hold at least 10 times the weight of the fixture through the safety cable eye on the fixture (see illustration on right).
6. Loosen the swivel locks, tilt the fixture to the desired angle, and retighten.
7. Verify that the fixture is at least 0.1 meters (4 in.) from the surface to be illuminated and at least 0.3 meters (12 in.) from any combustible materials. Verify that the clearance around the air vents is at least 0.1 meters (4 in.).

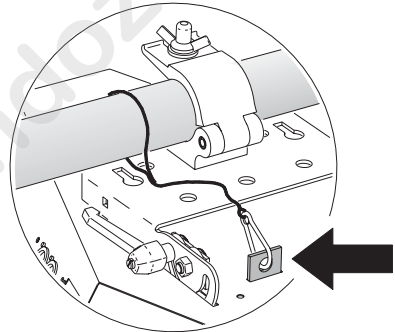

OPERATION FROM THE FLOOR

To operate the Wizard Extreme from the floor, you need the optional floor stand (P/N: 91606008).

The stand is designed for use on a flat surface. It is not intended to be used in any other way.

1. Attach the floor stand to the mounting bracket. The floor stand is longer at one end. Install the stand so that the long end is positioned

where the load is greatest. This will depend on the angle that the Wizard Extreme is set at.

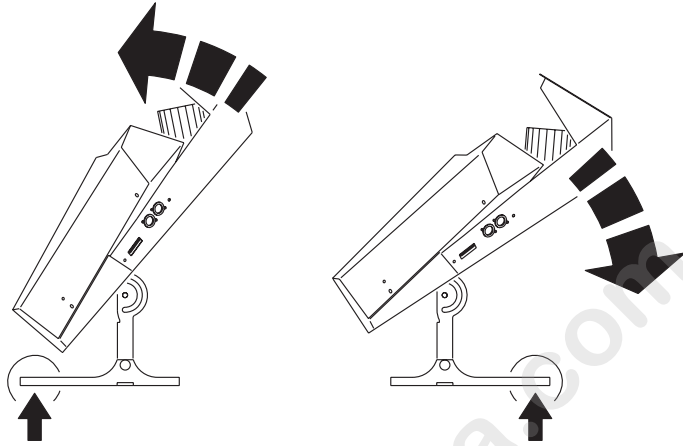

2. Place the fixture on the floor. Adjust the mounting bracket and tighten both swivel locks.
3. Verify that the fixture is stable, that it is at least 0.1 meters (4 in.) from the surface to be illuminated and at least 0.3 meters (12 in.) from any combustible materials. Verify that the clearance around the air vents is at least 0.1 meters (4 in.).

MULTI-COUPLER BRACKET

Installing multiple Wizard and/or Wizard Extremes can be made easier by using the Wizard multi-coupler bracket that is available as an accessory (P/N: 91606008).

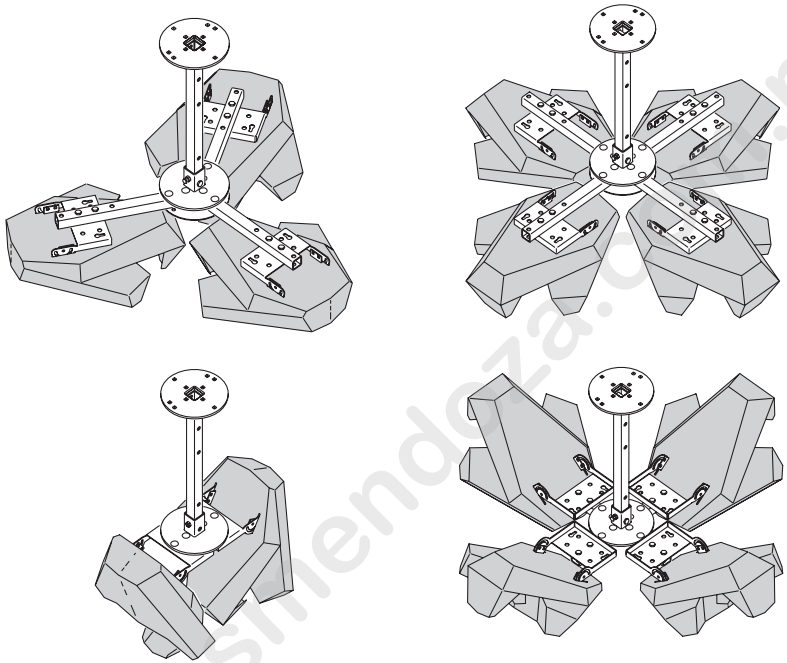

Example multi-coupler bracket installations

Instructions for installing Wizard Extreme fixtures on the multi-coupler bracket are supplied with the bracket. They are also available in the Wizard section of the Support area on the Martin website at <http://www.martin.com>

DATA CONNECTION

This section describes how to connect fixtures to each other, or to a controller.

RECOMMENDED CABLE

A reliable data connection requires suitable cable. Standard microphone cable cannot transmit DMX data reliably over long runs. For best results, use cable specifically designed for RS-485 applications. Your Martin dealer can supply suitable high-quality cable in various lengths.

CONNECTIONS

The Wizard Extreme's XLR data sockets are wired with pin 1 to ground, pin 2 to signal - (cold), and pin 3 to signal + (hot). This is compatible with the standard for DMX devices.

One or more adaptor cables may be required to connect the Wizard Extreme to the controller and/or other lights because many devices have 5-pin connectors and others may have reversed signal polarity, that is, pin 2 hot and pin 3 cold.



5-pin to 3-pin Adaptor	
Male	Female
1	1
2	2
3	3
4	
5	
P/N 11820005	



3-pin to 5-pin Adaptor	
Male	Female
1	1
2	2
3	3
	4
	5
P/N 11820004	

3-pin to 3-pin Phase-Reversing Adaptor	
Male	Female
1	1
2	2
3	3
P/N 11820006	

Connecting the data link

1. Connect a data cable to the controller's output. If controller has a 5-pin output, use a 5-pin male to 3-pin female adaptor cable (P/N 11820005).
2. Lead the data cable from the controller to the first fixture. Plug the cable into the fixture's data input.
3. Connect the output of the fixture closest to the controller to the input of the next fixture. If connecting two fixtures with opposing polarity on pins 2 and 3, insert a phase-reversing cable between the two fixtures.
4. Continue connecting fixtures output to input. Up to 32 devices may be connected on a serial link.
5. Terminate the link by inserting a male termination plug (P/N 91613017) into the data output of the last fixture. A termination plug is simply an XLR connector with a 120 ohm, 0.25 W resistor soldered across pins 2 and 3.

Male Termination Plug
Male XLR 1 2  120 Ohm 3  120 Ohm
P/N 91613017

Female Termination Plug
Female XLR 1 2  120 Ohm 3  120 Ohm
P/N 91613018

STAND-ALONE OPERATION

The Wizard Extreme can be operated without a DMX controller in stand-alone mode. A Wizard Extreme in stand-alone mode can be operated as a single unit or together with other Wizard Extremes in a “master/slave” configuration.

Several options are available in stand-alone operation. This chapter describes these options and explains how to select them using the DIP-switch.

Important! *The Wizard Extreme transmits a control signal when it is set as master (i.e. DIP-switch pins 2 and 10 are set to ON). To avoid damage to the electronics, do not connect more than 1 master to the data link.*

- *If you have Wizard Extremes set to single-unit operation and you want to connect them to a data link, set them as slaves before connecting them to the link.*
- *If you have a Wizard Extreme set as master and you want to use a different fixture on the data link as master, set the existing master to slave before you set the new master.*

SINGLE-UNIT OPERATION

The Wizard Extreme can be set to operate independently of other fixtures in either music trigger or auto trigger mode. No data link is needed for this mode of operation.

Single-unit operation, with options for trigger type and effect movement speed, can be selected as described under “Stand-alone settings” on page 19.

MASTER / SLAVE OPERATION

Multiple Wizard Extremes can be connected together on a data link without a controller for synchronized “master/slave” operation in which slave fixtures can be set to behave identically with, or respond to, the behavior of the master.

Fixtures must be connected in a 'daisy chain', i.e. the link must not be split into separate branches. It is possible to set any fixture as master, but it is most convenient to set the first fixture on the link.

Important! *Set only 1 fixture as master (DIP-switch pins 2 and 10 ON) or you may cause damage to your fixtures.*

Connecting units for master / slave operation

1. Connect the output of one Wizard Extreme to the input of the next.
2. Connect additional Wizard Extremes output to input. Up to 32 may be connected.
3. Terminate the link on both ends by inserting a *female* termination plug into the data *input* of the first fixture and a *male* termination plug into the data *output* of the last fixture. The female terminator may not be required if you set the first fixture on the link as master. A termination plug is simply an XLR connector with a 120 ohm, 0.25 W resistor soldered across pins 2 and 3.

Setting the master (auto trig)

1. Set DIP-switch pins 2 and 10 to ON.
2. Set DIP-switch pins 3, 5, 6, 7, 8, 9, and 11 to OFF.
3. Set DIP-switch pin 4 to ON for slow effects action or OFF for fast action (see "Stand-alone settings" on page 19).



Setting the master (music trig)

1. Set DIP-switch pins 1, 2 and 10 to ON.
2. Set DIP-switch pins 3, 5, 6, 7, 8, 9, and 11 to OFF.
3. Set DIP-switch pin 4 to ON for slow effects action or OFF for fast action (see "Stand-alone settings" on page 19).



Setting a slave

1. Set DIP-switch pin 10 to ON.
2. Set pins 1, 2, 3, 4, 5 and 11 to OFF.
3. Select options with DIP-switch pins 6, 7, 8, and 9 (see "Stand-alone settings" on page 19). If none of these options are set, the slave fixture will copy the master exactly. If one or more of these options is set, the slave fixture will be synchronized with the master but show different effects.



STAND-ALONE SETTINGS

DIP-switch pins 1-9 enable stand-alone options only when pin 10 is ON. When pin 10 is off, the DIP-switch selects a DMX address. *Pin 11 must be OFF for stand-alone operation.*

After setting DIP-switch 10, the Wizard Extreme must be powered off and then on again to activate or deactivate stand-alone operation.

Fixture	Option	Setting (0 = OFF, 1 = ON)										
		1	2	3	4	5	6	7	8	9	10	11
Single or master	Auto trigger, fast movement	0	1	0	0	0	0	0	0	0	1	0
	Auto trigger, slow movement	0	1	0	1	0	0	0	0	0	1	0
	Music trigger, fast movement	1	1	0	0	0	0	0	0	0	1	0
	Music trigger, slow movement	1	1	0	1	0	0	0	0	0	1	0
Slave	Identical to master	0	0	0	0	0	0	0	0	0	1	0
	Use a different color in relation to the master	0	0	0	0	0	1				1	0
	Use a different gobo in relation to the master	0	0	0	0	0		1			1	0
	Rotate the mirror drum in the opposite direction to the master	0	0	0	0	0			1		1	0
	Swivel the mirror drum in the opposite direction to the master	0	0	0	0	0				1	1	0

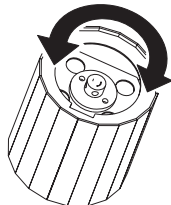

Mirror drum rotation

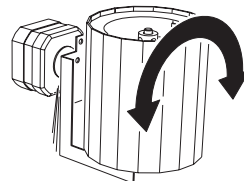

Mirror drum swivel

MC-1 OPERATION

The Wizard Extreme is fully compatible with the Martin MC-1 controller. This chapter explains how to configure the Wizard Extreme for operation with an MC-1. For further information, refer to the MC-1 user manual.

MC-1 SETTINGS

To control a Wizard Extreme using a Martin MC-1 controller, DIP-switch pin 10 must be set to OFF. The Wizard Extreme must also be set to Wizard emulation 8-channel mode by moving a jumper on the circuit board. This procedure is described in “*Setting Wizard emulation and 1-channel modes*” on page 32. Changes to these settings do not take effect until the fixture has been powered off and on.

DIP-switch pins 6, 7, 8, and 9 provide special options that are most useful when operating multiple Wizard Extremes from a single MC-1. Fixtures with these options selected will respond to the same commands but react differently than Wizard Extremes with standard settings. This allows you to make a light show more diverse but retain synchronized control of your fixtures.

Option	Setting (0 = OFF, 1 = ON)										
	1	2	3	4	5	6	7	8	9	10	11
Use a different color						1				0	1
Use a different gobo							1			0	1
Rotate the mirror drum in the opposite direction								1		0	1
Swivel the mirror drum in the opposite direction									1	0	1

DMX OPERATION

The Wizard Extreme can be connected to and operated from a DMX controller. To do this you need to:

1. Choose and set one of the three DMX modes. These three modes are described in the following sections, “*DMX modes*” and “*Setting the DMX mode*”
2. Set a DMX control address. This is described in “*DMX control address*” on page 24.

DMX MODES

The Wizard Extreme can be operated in three DMX modes:

- *11-channel mode* provides position control of all effects, plus twelve factory-set macros, plus control of mirror drum swivel rate, plus control of color and gobo wheel change speed.
- *Wizard emulation 8-channel mode* emulates the original best-selling Wizard fixture, providing position control of all effects, control of the mirror drum swivel rate, and color and gobo wheel change speed.
- *1-channel mode* allows control of the built-in stand-alone features during music trig operation

Full details of the 11-channel, Wizard emulation and 1-channel mode functions are listed in the DMX protocol sections on pages 35 - 40.

11-channel DMX operation

Channel 1 controls lamp on, lamp off, the dimmer and the strobe rate. It also allows you to execute a random “stand-alone” program using automatic or music trigger, and to reset all effects to their home positions.

Channel 2 controls the rotation of the mirror dish. This channel has no effect if the stand-alone program is selected on channel 1.

Channel 3 controls the color wheel and is used to select colors, split colors, the twinkle effect and color rotation. When the stand-alone program is running, this channel still has active control of the color wheel unless the DMX value is set to greater than 250 (>98%).

Channel 4 controls the color wheel shake function. Color wheel shake can be set to narrow or wide, and shake speed adjusted.

Channel 5 controls the gobo wheel. This channel functions even if the stand-alone program is selected. When the stand-alone program is running this channel still has active control of the gobo wheel, unless the DMX value is set to greater than 250 (>98%).

Channel 6 controls the gobo wheel shake function. Gobo wheel shake can be set to narrow or wide, and shake speed adjusted.

Channel 7 controls mirror drum swivel (pan) position and shake. This channel has no effect if the stand-alone program is running.

Channel 8 controls mirror drum rotation (tilt) direction, speed and shake. This channel has no effect if the stand-alone program is running.

Channel 9 allows one of 12 factory-set macros to be selected. The macros are mini-programs that use all the fixture's effects. Select a macro if you want fast access to impressive light effects with minimal programming.

Channel 10 controls the mirror drum swivel (pan) speed. Adjusting this allows you to program fades on controllers without faders. If fade times can be programmed on your controller and you use this function, turn the speed function off and set mirror drum swivel to tracking by setting channel 10 to zero. This channel has no effect if the stand-alone program is running.

Channel 11 provides speed control of the color and gobo wheels, allowing you to program slow or fast transitions from one effect position to another. This channel has no effect if the stand-alone program is running.

Wizard emulation 8-channel DMX operation

In Wizard emulation 8-channel mode, the Wizard Extreme emulates the original Wizard fixture, using the original Wizard's 8-channel extended DMX mode. If Wizard emulation mode is set, the Wizard Extreme can be added to an existing installation of Wizards and will behave exactly as if it was a Wizard in 8-channel mode.

Channel 1 controls lamp on, lamp off, the dimmer and the strobe rate. It also allows you to execute a random "stand-alone" program using automatic or music trigger, and to reset all effects to their home positions.

Channel 2 controls the rotation of the mirror dish. This channel has no effect if the stand-alone program is selected on channel 1.

Channel 3 controls the color wheel and is used to select colors, split colors, the twinkle effect and color rotation. When the stand-alone program is running, this channel still has active control of the color wheel unless the DMX value is set to greater than 250 (>98%).

Channel 4 controls the gobo wheel. This channel functions even if the stand-alone program is selected. When the stand-alone program is running, this channel still has active control of the gobo wheel unless the DMX value is set to greater than 250 (>98%).

Channel 5 controls the mirror drum's swivel (pan) position. This channel has no effect if the stand-alone program is running.

Channel 6 controls mirror drum rotation (tilt), direction and speed. This channel has no effect if the stand-alone program is running.

Channel 7 controls the mirror drum swivel (pan) speed. Adjusting this allows you to program fades on controllers without faders. If fade times can be programmed on your controller and you use this function, turn the speed function off and set mirror drum swivel to tracking by setting channel 7 to zero. This channel has no effect if the stand-alone program is running.

Channel 8 provides speed control of the color and gobo wheels, allowing you to program slow or fast transitions from one effect position to another. This channel has no effect if the stand-alone program is running.

1-channel DMX/music trig operation

Setting the Wizard Extreme to 1-channel operation can be useful if the number of channels available on your DMX controller is limited, but you still want some level of control over your fixtures.

If you set the Wizard Extreme to 1-channel DMX mode and select a stand-alone function, the fixture operates in music trig mode, but you can control of the following functions on the DMX channel. Note that multiple fixtures cannot be synchronized in this mode.

DMX value	Percent	Function
0-10	0-3	Light off
11-20	4-7	Light on
21-80	8-31	Strobe
81-115	32-44	Slow music trig (every 2 seconds)
116-140	45-54	Medium music trig (every second)
141-175	55-68	Fast music trig (every 0.2 seconds)
176-210	69-82	Random music trig (between 0.2-2.0 seconds)
211-255	83-100	Trigger whenever DMX value 240 is crossed

SETTING THE DMX MODE

1. Disconnect the fixture from power.
2. To set the Wizard Extreme to:
 - **11-channel DMX mode** set DIP-switch pins 10 and 11 to OFF.
 - **Wizard emulation 8 channel DMX mode** reset jumper PL118 on the circuit board (see “*Setting Wizard emulation and 1-channel modes*” on page 32) and set DIP-switch pins 10 and 11 to OFF.
 - **1-channel DMX mode** reset jumper PL118 on the circuit board (see “*Setting Wizard emulation and 1-channel modes*” on page 32) and set DIP-switch pin 10 to OFF and pin 11 to ON.

DMX CONTROL ADDRESS

The control address, also known as the start channel, is the first channel used to receive instructions from the controller. Each fixture needs its own control address set, and uses this address and subsequent control channels to receive instructions from a controller.

When the Wizard Extreme is in 11-channel mode, it reads the DMX data on the start channel and the next ten channels. If the DMX control address is set to 100, the fixture uses channels 100 - 110. Channel 111 is available for use as the control address for the next fixture.

If the Wizard Extreme is set to Wizard emulation 8-channel mode, it reads the DMX data on the start channel and the next seven channels.

If the Wizard Extreme is set to 1-channel mode, it reads the DMX data on the start channel only.

For independent control, a fixture must not use any DMX channel used by another fixture. If two or more fixtures are set up with the same address, they will receive the same instructions and should behave identically. Setting up identical fixtures with the same address is a good tool for troubleshooting unexpected behavior and an easy way to achieve synchronized action.

Specifying a DMX address

DIP-switch pins 1-9 are used to set the control address:

1. Select an address for the fixture on your controller. If you are calculating the DMX addresses for multiple fixtures, save time by using the Martin Address Calculator at <http://www.martin.dk/service/utilities/AddrCalc/index.asp>

2. Look up the DIP-switch setting using the Martin DIP Switch Calculator at <http://www.martin.dk/service/dipswitchpopup.htm> or look for the address in the DIP-switch settings table below.
3. Disconnect the fixture from power.
4. Set pins 1 through 9 to the ON (1) or OFF (0) position as listed in the table.

Find the address in the following table. Read the settings for pins 1 - 5 to the left and read the settings for pins 6 - 9 above the address. "0" means OFF and "1" means ON. Pin 10 is always OFF for DMX operation.

DIP-Switch Setting 0 = OFF 1 = ON					#9	0	0	0	0	0	0	0	0	1	1	1	1	1	1	1	1		
					#8	0	0	0	0	1	1	1	1	0	0	0	0	1	1	1	1	1	1
					#7	0	0	1	1	0	0	1	1	0	0	1	1	0	0	1	1	1	1
					#6	0	1	0	1	0	1	0	1	0	1	0	1	0	1	0	1	0	1
#1	#2	#3	#4	#5																			
0	0	0	0	0	32	64	96	128	160	192	224	256	288	320	352	384	416	448	480				
1	0	0	0	0	1	33	65	97	129	161	193	225	257	289	321	353	385	417	449	481			
0	1	0	0	0	2	34	66	98	130	162	194	226	258	290	322	354	386	418	450	482			
1	1	0	0	0	3	35	67	99	131	163	195	227	259	291	323	355	387	419	451	483			
0	0	1	0	0	4	36	68	100	132	164	196	228	260	292	324	356	388	420	452	484			
1	0	1	0	0	5	37	69	101	133	165	197	229	261	293	325	357	389	421	453	485			
0	1	1	0	0	6	38	70	102	134	166	198	230	262	294	326	358	390	422	454	486			
1	1	1	0	0	7	39	71	103	135	167	199	231	263	295	327	359	391	423	455	487			
0	0	0	1	0	8	40	72	104	136	168	200	232	264	296	328	360	392	424	456	488			
1	0	0	1	0	9	41	73	105	137	169	201	233	265	297	329	361	393	425	457	489			
0	1	0	1	0	10	42	74	106	138	170	202	234	266	298	330	362	394	426	458	490			
1	1	0	1	0	11	43	75	107	139	171	203	235	267	299	331	363	395	427	459	491			
0	0	1	1	0	12	44	76	108	140	172	204	236	268	300	332	364	396	428	460	492			
1	0	1	1	0	13	45	77	109	141	173	205	237	269	301	333	365	397	429	461	493			
0	1	1	1	0	14	46	78	110	142	174	206	238	270	302	334	366	398	430	462	494			
1	1	1	1	0	15	47	79	111	143	175	207	239	271	303	335	367	399	431	463	495			
0	0	0	0	1	16	48	80	112	144	176	208	240	272	304	336	368	400	432	464	496			
1	0	0	0	1	17	49	81	113	145	177	209	241	273	305	337	369	401	433	465	497			
0	1	0	0	1	18	50	82	114	146	178	210	242	274	306	338	370	402	434	466	498			
1	1	0	0	1	19	51	83	115	147	179	211	243	275	307	339	371	403	435	467	499			
0	0	1	0	1	20	52	84	116	148	180	212	244	276	308	340	372	404	436	468	500			
1	0	1	0	1	21	53	85	117	149	181	213	245	277	309	341	373	405	437	469	501			
0	1	1	0	1	22	54	86	118	150	182	214	246	278	310	342	374	406	438	470	502			
1	1	1	0	1	23	55	87	119	151	183	215	247	279	311	343	375	407	439	471	503			
0	0	0	1	1	24	56	88	120	152	184	216	248	280	312	344	376	408	440	472	504			
1	0	0	1	1	25	57	89	121	153	185	217	249	281	313	345	377	409	441	473	505			
0	1	0	1	1	26	58	90	122	154	186	218	250	282	314	346	378	410	442	474	506			
1	1	0	1	1	27	59	91	123	155	187	219	251	283	315	347	379	411	443	475	507			
0	0	1	1	1	28	60	92	124	156	188	220	252	284	316	348	380	412	444	476	508			
1	0	1	1	1	29	61	93	125	157	189	221	253	285	317	349	381	413	445	477	509			
0	1	1	1	1	30	62	94	126	158	190	222	254	286	318	350	382	414	446	478	510			
1	1	1	1	1	31	63	95	127	159	191	223	255	287	319	351	383	415	447	479	511			

BASIC SERVICE

This chapter describes the maintenance procedures that you can perform yourself:

1. "Cleaning"
2. "Lamp maintenance"
3. "Fuses"
4. "Setting Wizard emulation and 1-channel modes"
5. "Updating firmware"

CLEANING

Regular cleaning of the elements in the optical path, as well as the fans and air vents, is vital to maintaining the operational quality of the Wizard Extreme.

Cleaning intervals depend on the operating environment. Check fixtures regularly and clean if necessary.

Important! Excessive dust, smoke fluid, and particulate buildup degrades performance and causes overheating and damage to the fixture that is not covered by the warranty.

Cleaning the fan and air vents

To maintain adequate cooling, dust must be cleaned from the fan and air vents. The Wizard Extreme fan can be removed from the fixture to give access for cleaning.

To clean the fan:

1. Disconnect the fixture from power and allow it to cool completely.

2. Pull the two locking pins on the fan up to release it, and lift up the outer edge of the fan (illustration A).

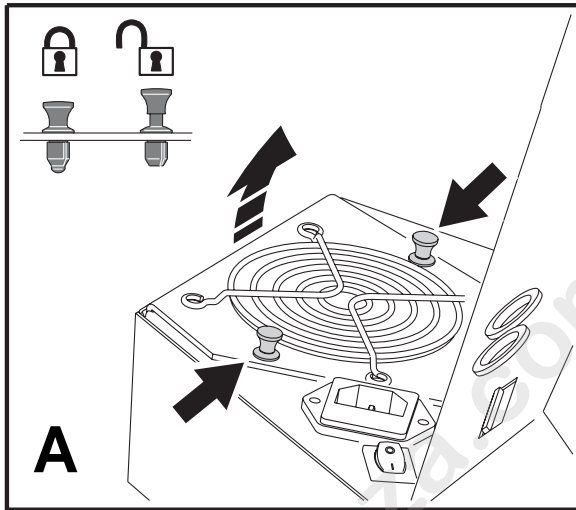

3. Slide the fan out of the fixture housing (illustration B).

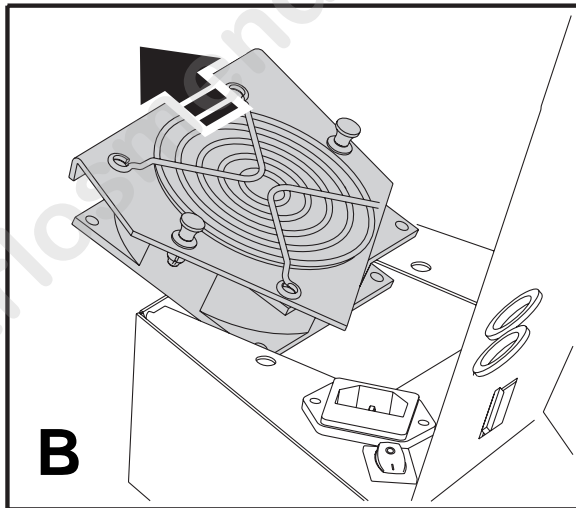

4. When the fan is clear of the housing, lift it up for access to the fan blades.
5. Remove dust from the fan and grille with a soft brush, cotton swab, vacuum, or compressed air.
6. Replace the fan in the housing and push down on the two locking pins to secure it.

Cleaning optical components

Clean the optical components regularly. The presence of smudges or dust on optical surfaces can reduce the strength of the light output and the quality of the effects.

The following illustration shows the elements that need to be kept clean:

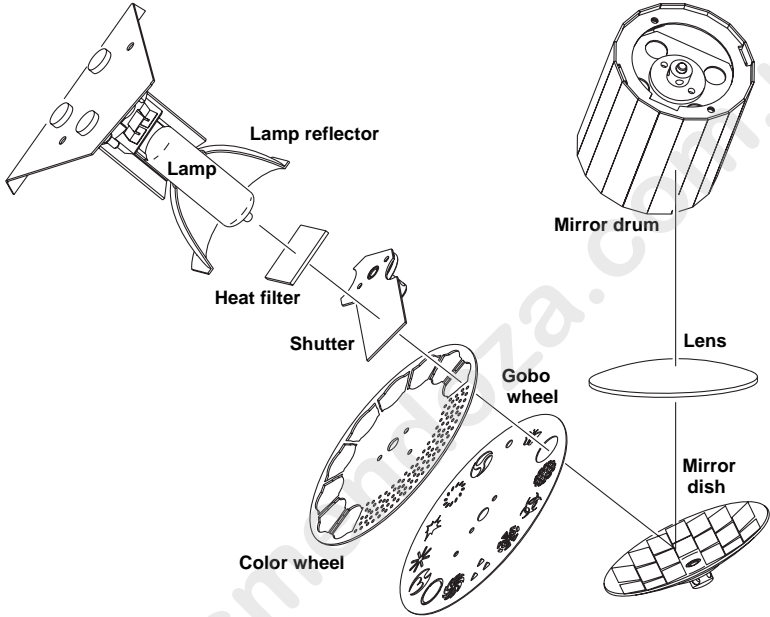

Use care when cleaning optical components and work in a clean, well lit area. The coated surfaces are fragile and easily scratched. Do not use solvents that can damage plastic or painted surfaces.

1. Disconnect the fixture from power and allow the components to cool completely.
2. Remove the fixture cover. You may want to remove the lamp for cleaning (see the related steps in *“Installing a lamp in the Wizard Extreme”* on page 29).
3. Vacuum or gently blow away dust and loose particles with compressed air.
4. Remove stuck particles with an unscented tissue or cotton swab moistened with glass cleaner or distilled water. Do not rub the surface: lift the particles off with a soft repeated press.
5. Remove smoke and other residues with cotton swabs or unscented tissues moistened with isopropyl alcohol. A commercial glass cleaner may be used, but residues must be removed with distilled water. Clean

with a slow circular motion from center to edge. Dry with a clean, soft and lint-free cloth or compressed air.

6. Replace the fixture cover (and lamp-access cover) before applying power.

LAMP MAINTENANCE

The Wizard Extreme is supplied with an Osram HSD 250W/80 long-life discharge lamp installed. This lamp has an average life of 3000 hours, a color temperature of 8000 K and a color rendering index greater than 85.

Lamp envelopes weaken with age, so to reduce the risk of lamp explosion replace the lamp when it reaches the limit of its service life as specified by the manufacturer.

The following lamp types are supported:

- Osram HSD 250/80
- Osram HSD 250/78
- Osram HSD 250/60
- Philips MSD 250/2
- Philips MSD 200

Important! *Installing any other lamp may damage the fixture.*

Allow the lamp to cool for at least 5 minutes before packing and moving the fixture. To avoid possible damage, remove the lamp when shipping the fixture.

Warning! *Always disconnect the fixture from AC power and allow it to cool for at least 5 minutes before installing the lamp. The screws on the lamp plate can reach 90° C (194° F) during operation.*

Installing a lamp in the Wizard Extreme

1. Disconnect the fixture from AC power. If replacing a lamp, allow it to cool for at least 5 minutes before removing the lamp-access cover. The lamp cools faster with the cover in place. It can take up to 15 minutes for the fixture to cool completely.
2. Remove the two lamp access screws from the lamp-access cover, and lift the cover off.

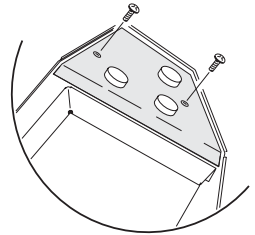

3. If replacing a lamp, grasp the old lamp by the reflector and pull it out of the holder. Then pull the socket off the lamp. Do not pull the wires.
4. Push the socket fully onto the pins of the new lamp.
5. Clean the glass bulb with the cloth supplied with the lamp, particularly if your fingers touched the glass. A clean, lint-free cloth wetted with alcohol may also be used.
6. Gently push the lamp into the holder until it snaps into place.
7. Replace the lamp-access cover and screws.

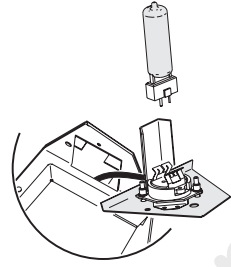

Adjusting the lamp

The Wizard Extreme lamp assembly is adjusted at the factory. Due to differences between lamps, however, fine adjustment may improve performance.

1. Disconnect the fixture from AC power.
2. If you are:
 - Using a controller, turn on the Wizard Extreme and select white light with the open gobo.
 - Not using a controller, flip DIP-switch pins 3 and 10 on. Flip all other pins off. Apply power to the Wizard Extreme. After it has reset, the fixture produces a white light with an open gobo for adjustment purposes.
3. Wait for the lamp to reach full brightness.
4. To reduce the number of images, deflect the light stream away before it strikes the mirror drum by holding a small hand-held mirror in front of it. Lamp adjustment is also easier if you reflect onto a white surface.

5. Make adjustments using the three lamp-adjustments screws:

- If there are off-center “hot spots” in the images then the lamp is not centered in the reflector. Pull the hot spots into the center of the image fields with small adjustments of the lamp-adjustment thumbscrews.
- If the light is brighter in the center of the images than it is at the edge, then the lamp is too far forward in the reflector. Pull the lamp

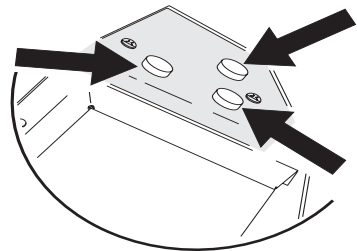

in by turning all three screws clockwise 1/4-turn at a time until the light is evenly distributed.

- If the light is brighter around the edge of the images than it is in the center, or if light output is low, then the lamp is too far back in the reflector. "Push" the lamp out by turning the screws counterclockwise 1/4-turn at a time until the light is bright and evenly distributed.

FUSES

The Wizard Extreme uses a time-delay fuse for protection against current overload. If the power LED does not light when power is applied, the fuse may be spent. If the fuse blows repeatedly, there is a fault with the unit that requires service by a Martin technician.

Never bypass the fuse or replace it with one of another size or rating.

Replacing the main fuse

1. Unplug the mains cable from the input socket.
2. Pry open the fuse holder, which is built into the input socket, and remove the fuse.
3. Replace the fuse with one of the same type. The fuse rating is listed on the serial number label that can be found on the back of the fixture.

SETTING WIZARD EMULATION AND 1-CHANNEL MODES

The Wizard Extreme is factory-set to operate in 11-channel DMX mode. To operate in Wizard emulation 8-channel or 1-channel DMX modes, an adjustment is required:

1. Disconnect the fixture from power and allow to cool.
2. Remove the fixture cover.
3. Locate jumper PL118 on the printed circuit board next to the DIP-switch (see arrow in illustration on right). If the Wizard Extreme is set to 11-channel mode, the jumper cap will only be sitting on one of the pins.
4. Using a pair of tweezers or similar tool, lift off the jumper cap and place it on both of the pins to enable Wizard emulation 8-channel or 1-channel DMX operation.
5. Replace the cover before applying power.

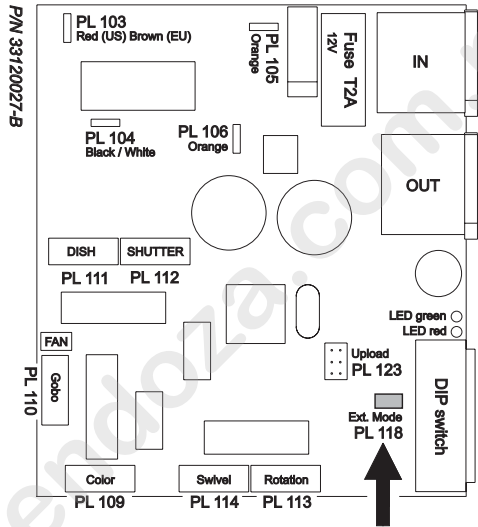

To return the Wizard Extreme to 11-channel DMX mode, repeat the above procedure, but place the jumper cap on only one of the pins.

UPDATING FIRMWARE

Firmware updates are released when features are added or bugs are fixed. The latest version is available from your Martin dealer, or the support area of the Martin web site at <http://www.martin.com>

The installed firmware version is displayed by the Power and Data LEDs, located next to the DIP switches, when power is applied to the fixture and all DIP switch pins are set to OFF. The red LED (Power) indicates the number to the left of the decimal point and the green LED (Data) indicates

the number to the right. For example, if firmware version 1.4 is installed, the red LED flashes once and the green LED flashes four times.

Firmware is installed using a Martin uploader or a DMX interface for the Martin LightJockey controller. The procedure is found in the MP-2 user manual and the Martin Software Uploader online help file.

REQUIREMENTS

The following are required in order to install software.

- The Wizard Extreme update file, available for download from the User Support Area of the Martin web site (<http://www.martin.com>).
- The Martin Software Uploader program, version 4.0 or later, available for download from the User Support Area of the Martin web site.
- A Martin MP-2 Uploader connected to a Windows 95/98/ME/2000 PC, or a LightJockey Controller with DMX Interface card.

Updating fixture firmware with the MP-2 Uploader

1. Connect a prepared MP-2 Uploader to the DMX link. Apply power to the fixtures and the MP-2. Wait a few moments for the fixtures to reset.
2. Select **Read Memory Card** from the MP-2 main menu.
3. Use the buttons on the right to scroll through the card slots. Select the slot that holds the desired version of the Wizard Extreme firmware.
4. Select **Update Software**. Select **Yes** to confirm.
5. Select **Update in DMX mode** to start the upload. The MP-2 initializes all connected Wizard Extremes, which respond with two yellow LEDs in the status display. Avoid interrupting the process: this will corrupt the software.
6. After a successful upload, the fixtures reset with the new software. If an error occurs and the fixtures do not reset, data was interrupted or corrupted during transmission.

TROUBLESHOOTING

Problem	Probable cause(s)	Remedy
Fixture is completely dead.	No power to fixture.	Check that power is switched on and cables are plugged in.
	Primary fuse blown.	Replace fuse.
	Secondary fuse blown.	Contact Martin technician for service.
Fixture resets correctly but does not respond to controller.	The DMX signal is not transmitted.	Connect controller. Inspect connections and cables. Correct poor connections. Repair or replace damaged cables.
	The DMX data signal is reversed.	Insert a phase-reversing cable in the link before the fixture.
	Incorrect address or other DIP-switch setting.	Check DIP-switch settings.
Intermittent flicker or strange behavior.	Data link not terminated.	Insert termination plug in output of the last fixture on the link.
	One of the fixtures is transmitting as a master or is defective.	Bypass one fixture at a time until normal operation is regained: unplug both connectors and connect them directly together. Have the defective fixture serviced by a qualified technician.
Effect fails to reset correctly.	The effect requires mechanical adjustment.	Contact Martin technician for service.
No light.	Lamp missing or blown	Disconnect fixture and replace lamp.
Lamp cuts out intermittently or burns out too quickly.	The operating voltage does not match AC supply.	Contact Martin technician for service.
	Blocked air vent.	Increase clearance around fixture.
	Dust buildup inside fixture.	Contact Martin technician for professional cleaning.
	The fan may not be working. This will result in the thermostatic switch cutting power to the lamp when the fixture overheats. When the fixtures cools the lamp will come on again, causing the fixture to heat, which will again trip the thermostatic switch, and so forth.	Contact Martin technician for service.

DMX PROTOCOL: 11-CHANNEL MODE

Channel	Value	Percent	Function
1	0-1	0	Light, Strobe, Music trig, Reset Shutter on (light off)
	2-129	1-50	Dimmer (100-0%) & Lamp on
	130-189	51-74	Strobe (fast to slow)
	190-199	75-78	Shutter on (light off)
	200-209	79-82	Random strobe
	210-219	83-86	Stand-alone music trig
	220-229	87-90	Stand-alone autotrig
	230-239	91-94	Shutter On
	240-249	95-98	Reset (when set for > 5 sec.)
	250-255	99-100	Lamp off (when set for > 5 sec. & channels 2 & 3 > 252)
2	0-1	0	Mirror dish No rotation
	2-63	1-24	Clockwise rotation (slow to fast)
	64-65	25	No rotation
	66-127	26-49	Counter clockwise rotation (fast to slow)
	128-129	50	No rotation
	130-190	51-74	Narrow shake (slow to fast)
	191-254	75-99	Wide shake (slow to fast)
255	100	Random shake	
3	0-5	0-1	Color 0 Open
	6-11	2-4	1 Open / Blue
	12-17	5-6	2 Blue 108
	18-23	7-8	3 Blue / Orange
	24-29	9-10	4 Orange 306
	30-35	11-13	5 Orange / Purple
	36-41	14-15	6 Purple 502
	42-47	16-17	7 Purple / Green
	48-53	18-20	8 Green 206
	54-59	21-22	9 Green / Blue
	60-65	23-25	10 Blue 101
	66-71	26-27	11 Blue / Yellow
	72-77	28-29	12 Yellow 603
	78-83	30-32	13 Yellow / Magenta
	84-89	33-35	14 Magenta 507
	90-95	36-37	15 Magenta / Open
	96-101	38-39	16 Open
	102-169	40-66	Color rotation (slow to fast)
	170-175	67-68	No rotation
	176-243	69-95	Twinkle rotation (slow to fast)
244-249	96-97	No rotation	
250-255	98-100	Remote stand-alone music trig and auto trig	

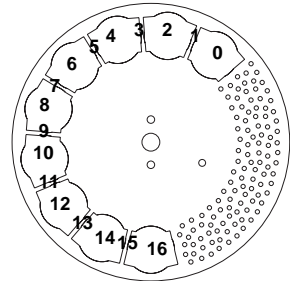

Channel	Value	Percent	Function
4	0-1	0	Color shake No shake
	2-128	1-50	Narrow shake (slow to fast)
	129-255	51-100	Wide shake (slow to fast)
5	0-10	0-3	Gobo 0 Open
	11-22	4-8	1 Starz
	23-34	9-13	2 Zapp
	35-46	14-17	3 Pipes
	47-58	18-22	4 Triple dot
	59-70	23-26	5 Crazy circles
	71-82	27-31	6 Cone
	83-94	32-36	7 Sun
	95-106	37-41	8 Spokes
	107-118	42-46	9 Bars
	119-130	47-50	10 Gyroblast
	131-142	51-55	11 Happy yins
	143-154	56-60	12 Dot
	155-169	61-66	13 Weave
	170-239	67-94	Wheel rotation (slow to fast)
	240-249	95-97	No rotation
250-255	98-100	Remote stand-alone music trig and auto trig	
6	0-1	0	Gobo shake No shake
	2-128	1-50	Narrow shake (slow to fast)
	129-255	51-100	Wide shake (slow to fast)
7	0	0	Mirror drum swivel (pan) Max Left
	63	24	Neutral
	127	50	Max Right
	128-191	51-74	Narrow shake (slow-fast)
	255	75-100	Wide shake (slow-fast)
8	0-1	0	Mirror drum rotation (tilt) No rotation
	2-63	1-24	Clockwise rotation (slow to fast)
	64-65	25	No rotation
	66-127	26-49	Counterclockwise rotn. (fast to slow)
	128-129	50	No rotation
	130-191	51-74	Narrow shake (slow-fast)
	192--255	75-100	Wide shake (slow-fast)

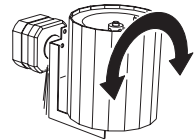
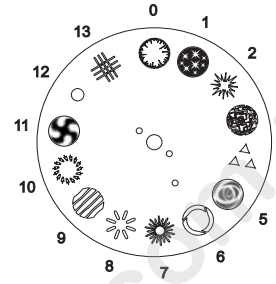

Channel	Value	Percent	Function
9	0-15	0-5	Macros Macro 1
	16-31	6-11	Macro 2
	32-47	12-18	Macro 3
	48-63	19-24	Macro 4
	64-79	25-30	Macro 5
	80-95	31-37	Macro 6
	96-111	38-43	Macro 7
	112-127	44-49	Macro 8
	128-143	50-55	Macro 9
	144-159	56-62	Macro 10
	160-175	63-68	Macro 11
	176-191	69-74	Macro 12
	192-255	75-100	Reserved: no function
10	0-1	0	Mirror drum swivel (pan) speed Tracking
	2-255	1-100	Fast to slow
11	0-255	0-100	Color and gobo speed Fast to slow

DMX PROTOCOL: WIZARD EMULATION 8-CHANNEL MODE

Channel	Value	Percent	Function
1	0-1	0	Light
	2-129	1-50	Shutter closed
	130-189	51-74	Dimmer (closed-open) & Lamp on
	190-199	75-78	Strobe (fast to slow)
	200-209	79-82	Shutter closed
	210-219	83-86	Random strobe
	220-229	87-90	Stand-alone music trig
	230-239	91-94	Stand-alone auto trig
	240-249	95-98	Shutter closed
	250-255	99-100	Reset (hold for >5 seconds) Lamp off (when set for > 5 seconds & channel 3 & 4 > 252)
2	0-1	0	Mirror dish rotation
	2-122	1-47	No rotation
	123-132	48-51	Clockwise rotation (slow to fast)
	133-253	52-99	No rotation
	254-255	100	Counter clockwise rotation (fast to slow) No rotation
3	0-5	0-1	Color
	6-11	2-4	0 Open
	12-17	5-6	1 Open / Blue
	18-23	7-8	2 Blue / 108
	24-29	9-10	3 Blue / Orange
	30-35	11-13	4 Orange / 306
	36-41	14-15	5 Orange / Purple
	42-47	16-17	6 Purple / 502
	48-53	18-20	7 Purple / Green
	54-59	21-22	8 Green / 206
	60-65	23-25	9 Green / Blue
	66-71	26-27	10 Blue / 101
	72-77	28-29	11 Blue / Yellow
	78-83	30-32	12 Yellow / 603
	84-89	33-35	13 Yellow / Magenta
	90-95	36-37	14 Magenta / 507
	96-101	38-39	15 Magenta / Open
	102-169	40-66	16 Open
	170-175	67-68	Color rotation (slow to fast)
	176-243	69-95	No rotation
	244-249	96-97	Twinkle rotation (slow to fast)
250-255	98-100	No rotation Remote stand-alone music trig and auto trig	

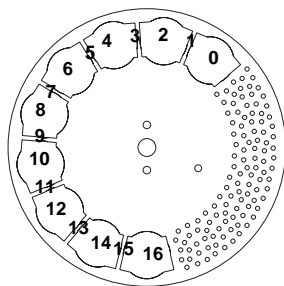

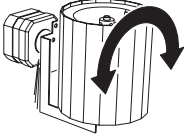
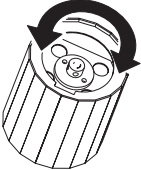
Channel	Value	Percent	Function
4	0-10	0-3	Gobo 0 Open
	11-22	4-8	1 Starz
	23-34	9-13	2 Zapp
	35-46	14-17	3 Pipes
	47-58	18-22	4 Triple dot
	59-70	23-26	5 Crazy circles
	71-82	27-31	6 Cone
	83-94	32-36	7 Sun
	95-106	37-41	8 Spokes
	107-118	42-46	9 Bars
	119-130	47-50	10 Gyroblast
	131-142	51-55	11 Happy yins
	143-154	56-60	12 Dot
	155-169	61-66	13 Weave
	170-239	67-94	Wheel rotation (slow to fast)
	240-249	95-97	No rotation
	250-255	98-100	Remote stand-alone music trig and auto trig
5	0	0	Mirror drum swivel (pan) Max Left
	127	50	Neutral
	255	100	Max Right
			
6	0-1	0	Mirror drum rotation (tilt) No rotation
	2-122	1-48	Clockwise rotation (slow to fast)
	123-132	49-52	No rotation
	133-253	53-99	Counter clockwise rot. (fast to slow)
	254-255	100	No rotation
			
7	0-1	0	Mirror drum swivel (pan) speed Tracking
	2-255	1-100	Fast to slow
8	0-255	0-100	Color and gobo wheel speed Fast to slow

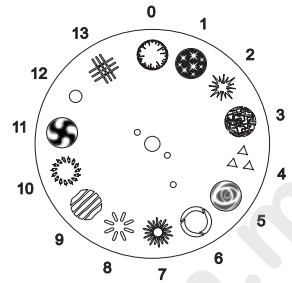

DMX PROTOCOL: 1-CHANNEL MODE

Channel	DMX value	Percent	Function
1	0-10	0-3	Light off
	11-20	4-7	Light on
	21-80	8-31	Strobe
	81-115	32-44	Slow music trig (every 2 seconds)
	116-140	45-54	Medium music trig (every second)
	141-175	55-68	Fast music trig (every 0.2 seconds)
	176-210	69-82	Random music trig (between 0.2-2.0 seconds)
	211-255	83-100	Trigger whenever DMX value 240 is crossed

WIZARD EXTREME SPECIFICATIONS

PHYSICAL

- Size (L x W x H) 552 x 516 x 208 mm (21.7 x 20.3 x 8.2 in)
- Weight 14.5 kg (32 lbs)

CONSTRUCTION

- Housing steel
- Finish electrostatic powder coating
- Color black

THERMAL

- Maximum ambient temperature (T_a) 40° C (104° F)
- Maximum surface temperature 90° C (194° F)
- Total heat dissipation 1092 Btu/hr @ 320 W, 1058 Btu/hr @ 310 W

INSTALLATION

- Minimum distance to combustible materials 0.3 m (12 in)
- Minimum distance to illuminated surfaces 0.1 m (4 in)
- Minimum clearance around fans and vents 0.1 m (4 in)
- Orientation any
- Mounting points two slotted & six standard 13 mm holes in bracket.

Rigging options

- Overhead or wall mounting
- Floor operation with floor stand accessory
- Mounting in Multi-coupler Bracket accessory

CONTROL AND PROGRAMMING

- Data I/O sockets.. 3-pin XLR male/female, pin 1=shield, pin 2 (-), pin 3 (+)
- Control protocol USITT DMX-512 (1990)
- Electrical standard RS-485
- DMX modes 1-, 11- or 8-channel
- Stand-alone triggers music or auto
- Control method DMX controller, stand-alone, master/slave

ELECTRICAL, EU MODEL

- Input 3-prong IEC male socket
- AC Power 230 / 240 / 250 V, 50 Hz
- Main fuse 3.15 A T (time delay), P/N 05020013
- Circuit board fuse 2 A T (time delay), P/N 05020009

- Maximum power and current @ 230 V, 50 Hz 320 W, 1.5 A
- Maximum power and current @ 240 V, 50 Hz 320 W, 1.6 A
- Maximum power and current @ 250 V, 50Hz 310 W, 1.4 A

ELECTRICAL, US MODEL

- Input 3-prong IEC male socket
- AC power 100 / 120 / 230 / 250 V, 50 / 60 Hz
- Main fuse 6.3 A T (time delay), P/N 05020020
- Circuit board fuse 2 A T (time delay), P/N 05020009
- Maximum power and current @ 100 V, 50 Hz 320 W, 3.8 A
- Maximum power and current @ 100 V, 60 Hz 310 W, 3.4 A
- Maximum power and current @ 120 V, 50 Hz 320 W, 2.9 A
- Maximum power and current @ 120 V, 60Hz 310 W, 2.7 A
- Maximum power and current @ 230 V, 50Hz 320 W, 1.5 A
- Maximum power and current @ 230 V, 60Hz 320 W, 1.5 A
- Maximum power and current @ 250 V, 50 Hz 310 W, 1.4 A
- Maximum power and current @ 250 V, 60 Hz 320 W, 1.3 A

APPROVALS



- EU EMC EN 55103-1, EN 55103-2
- EU safety EN 60598-2-17
- Canadian safety CSA C22.2 NO 166
- US safety ANSI/UL 1573

LAMP SPECIFICATIONS

Osram HSD 250/80

- Type discharge
- Power 250 watts
- Rated life 3000 hours
- Color temperature 8000 K

Osram HSD 250/60

- Type discharge
- Power 250 watts
- Rated life 2000 hours
- Color temperature 6000 K

Philips MSD 250/2

- Type discharge
- Power 250 watts
- Rated life 3000 hours
- Color temperature 8500 K

Philips MSD 200

- Type discharge
- Power 200 watts
- Rated life2000 hours
- Color temperature 6000 K

INCLUDED ITEMS

- Osram HSD 250/80 lamp (installed) P/N 97010116
- User manual P/N 35000155
- Mains cable, EU model:
 - 3x1,0mm² IEC-Schuko P/N 11501020
 - 3x1,0mm² Open wire P/N 11501010
- Mains cable, US model:
 - 3x18AWG IEC-US, 3M P/N 11501502

ACCESSORIES

- Osram HSD 250/80 lamp P/N 97010116
- Osram HSD 250/60 lamp P/N 97010103
- Philips MSD 250/2 lamp P/N 97010100
- Philips MSD 200 lamp P/N 97010106
- Half-coupler clamp P/N 91602005
- Wizard multi-coupler (for rigging multiple fixtures) P/N 91606010
- Wizard floor stand P/N 91606008

ORDERING INFORMATION

- Wizard Extreme, EU model P/N 90426200
- Wizard Extreme, US model P/N 90426300

www.carlosmendoza.com.mx

Martin

www.martin.dk • Olof Palmes Allé 18 • 8200 Aarhus N • Denmark
Tel: +45 8740 0000 • Fax +45 8740 0010