

RoboScan Pro 218

User Manual

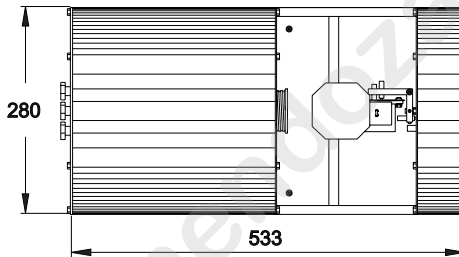

ROBOSCAN PRO 218

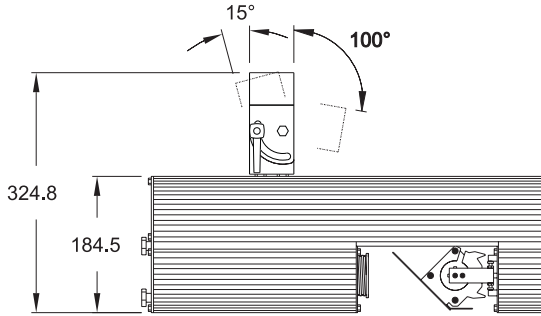

(dimensions in millimeters)

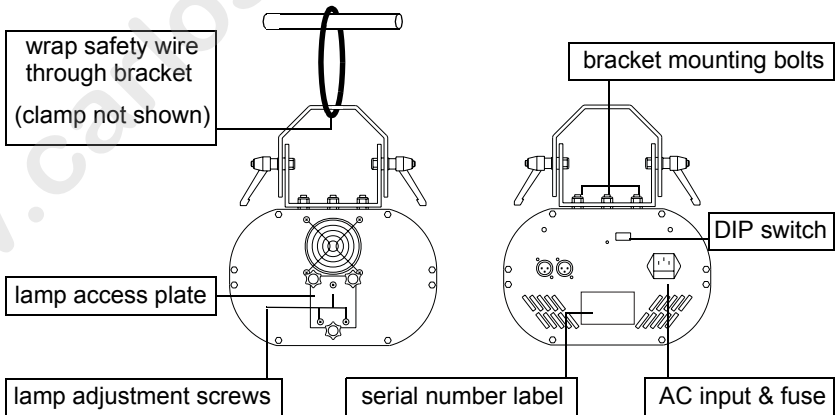

section 1 INTRODUCTION

Thank you for purchasing the Martin RoboScan Pro 218 moving-mirror intelligent projector. It is designed and built to be bright, reliable, and easy to use. With proper setup and maintenance, the RoboScan Pro 218 will provide years of trouble-free operation.

This manual covers software version 1.4. The latest product information is always available from your dealer and the Martin web site at <http://www.martin.dk>.

Safety Information

WARNING!

This product is for professional use only. It is not for household use.

This product presents risks of lethal or severe injury due to fire and heat, electric shock, ultraviolet radiation, lamp explosion, and falls. **Read this manual** before powering or installing the fixture, follow the safety precautions listed below and observe all warnings in this manual and printed on the fixture. If you have questions about how to operate the fixture safely, please contact your Martin dealer or call the Martin hotline at +45 70 200 201.

To protect yourself and others from electric shock

- Disconnect the fixture from AC power before removing or installing the lamp, fuses, or any part, and when not in use.
- Always ground (earth) the fixture electrically.
- Use only a source of AC power that complies with local building and electrical codes and has both overload and ground-fault protection.
- Do not expose the fixture to rain or moisture.
- Refer any service operation not described in this manual to a qualified technician.

To protect yourself and others from UV radiation and lamp explosion

- Never operate the fixture with missing or damaged lenses and/or covers.
- When replacing the lamp, allow the fixture to cool for at least 5 minutes before opening the fixture or removing the lamp. Protect your hands and eyes with gloves and safety glasses.
- Do not stare directly into the light. Never look at an exposed lamp while it is lit.
- Replace the lamp if it becomes defective or worn out, or before usage exceeds 110 percent of the rated average life.

To protect yourself and others from burns and fire

- Never attempt to bypass the thermostatic switch or fuses. Always replace defective fuses with ones of the specified type and rating.
- Keep all combustible materials (such as fabric, wood, paper) at least 0.3 meters (12 inches) away from the fixture. Keep flammable materials well away from the fixture.
- Do not illuminate surfaces within 0.3 meters (12 inches) of the fixture.
- Provide a minimum clearance of 0.1 meters (4 inches) around fans and air vents.
- Never place filters or other materials over the lens or mirror.
- The fixture can get very hot. Allow it to cool for at least 5 minutes before handling.
- Do not modify the fixture or install other than genuine Martin parts.
- Do not operate the fixture if the ambient temperature (Ta) exceeds 40° C (104° F).

To protect yourself and others from injury due to falls

- When suspending the fixture above ground level, verify that the structure can hold at least 10 times the weight of all installed devices.
- Verify that all external covers and rigging hardware are securely fastened and use an approved means of secondary attachment such as a safety cable.
- Block access below the work area whenever installing or removing the fixture.

Features

- High intensity long-life discharge lamp: the 200 watt Philips MSD 200 or the 150 watt GE Lighting Arcstream, depending on model.
- 17 dichroic colors plus white (including two multicolors).
- 17 motorized gobos plus open white.
- 0 to 100% dimming.
- High-speed shutter for instant blackout and strobe effects.
- Variable speed and tracking control.
- Split colors.
- Coated precision optics with adjustable focus.
- Compatibility with Martin and DMX-512 control protocols.
- Built-in random chases with or without music trigger.
- Power Factor Correction for low current consumption.
- Overheating protection.

Accessories

Your Martin dealer can provide you with the following RoboScan Pro 218 accessories:

- 2-unit flight case P/N 91505000
- 4-unit flight case P/N 91505001
- Floor stand P/N 00500109

section 2

INSTALLATION

The RoboScan Pro 218 package includes the following items:

- Mounting bracket
- 5 meter XLR-XLR cable
- Power cable
- User manual

The RoboScan Pro 218 is delivered fully adjusted from the factory; only a few installation procedures are necessary.

Connecting to the power supply

WARNING!

For safe operation, the fixture must be grounded (earthed).

1. The RoboScan Pro 218 may be delivered from the factory without a plug on the power cable. To install a suitable plug (one that fits your local AC outlet), connect the brown wire to the LIVE pin, the blue wire to the NEUTRAL pin, and the yellow/green wire to the GROUND pin (earth).
2. Make sure that the factory settings for voltage and frequency match your local power supply. If this is not the case, then rewire the RoboScan Pro 218 as described in the Maintenance section. The factory setting is printed on the serial number label located on the front of the fixture.
3. Do not apply power to the fixture until the DIP-switch is set as described in the following sections.

Installing the lamp

The RoboScan Pro 218 is available with either the MSD 200 lamp from Philips or the Arc-stream lamp from GE Lighting. **These lamps, however, are not interchangeable. Using a lamp other than the one specified may damage the fixture.** The correct lamp is printed on the label on the front of the Pro 218. See the specifications for additional lamp information.

WARNING!

Before installing the lamp, make sure the fixture is disconnected from AC power.

1. Remove the 3 thumbscrews securing the access plate to the back of the RoboScan and withdraw the lamp-socket assembly.
2. Holding the lamp in a clean cloth to avoid touching the glass bulb, carefully insert the lamp into the socket.
3. Clean the lamp with the supplied cloth, particularly if you have touched the glass bulb.
4. Replace the lamp-socket assembly and tighten the thumbscrews.

Releasing the pan/tilt lock

To protect the pan/tilt assembly from damage during shipment, it has been secured with two plastic straps and two thumbscrews.

1. Cut and remove the plastic straps.
2. Remove the two thumbscrews on either side of the pan/tilt assembly and store them in the two threaded holes, B1 and B2, located on the pan/tilt plate.
3. Carefully remove the surface protection foil and warning notice from the mirror.

The entire pan/tilt assembly floats in a special rubber mount. This reduces noise when operating the pan and tilt motors, thus ensuring silent operation. **It is strongly suggested that the pan/tilt assembly be secured during transportation** by replacing the two thumbscrews in positions A1 and A2 on either side of the pan/tilt assembly.

Installing the mounting bracket

1. Place the mounting bracket over the three mounting bolts on the top of the chassis and secure it with the three M8 self-locking nuts.
2. When rigging the fixture, **wind an approved safety cable through the mounting bracket and truss.**

section 3

STAND-ALONE OPERATION

The RoboScan Pro 218 may be operated without a controller in stand-alone mode, in which the fixture performs a random sequence on its own. To operate the fixture in this mode:

1. Use the DIP-switch on the front of the fixture to select a stand-alone sequence. The following table shows the various DIP-switch settings. "Music-trig" sequences use the beat of the music, picked up by the built-in microphone, to trigger the sequence. "Auto-trig" sequences run at a preset speed.
2. Apply power to the fixture to run the selected sequence.

STAND-ALONE SEQUENCE SETTINGS

Description	Pins switched ON
Stand-alone, wide pan/tilt, auto trigger	2, 10
Stand-alone, wide pan/tilt, music trigger	1, 2, 10
Stand-alone, narrow pan/tilt, auto trigger	2, 3, 10
Stand-alone, narrow pan/tilt, music trigger	1, 2, 3, 10
Lamp adjust	8, 10
Adjustment sequence (for service use only)	(1), 5, 10
Adjustment sequence (for service use only)	(1), 6, 10
L.E.D. chase auto-trig (for service use only)	4, 10
L.E.D. chase music-trig (for service use only)	1, 4, 10

section 4

CONTROLLER OPERATION

The RoboScan Pro 218 may be operated with both DMX-512 and Martin RS-485 protocol controllers. Instructions are transmitted from the controller via an XLR - XLR cable to the data input on the RoboScan. The data output allows the serial data link to be continued to additional fixtures.

To connect a serial data link:

1. Connect the data output of the controller to the data input on the Pro 218. If using a Martin controller, use the XLR-XLR / DSUB-XLR cable that came with the controller. Otherwise, use a cable that fits the DMX controller and the RoboScan. This is normally a cable that adapts from 5-pin XLR to 3-pin XLR. The following table shows the pin connections. Note that the (+) and (-) wires swap from the DMX output to the input on the RoboScan Pro 218. (The cable is available from Martin as P/N 11820003.)
2. If only using one fixture, insert an XLR termination plug into the data output socket on the RoboScan. If a Martin controller is being used, then insert the termination plug that came with the controller (120 Ohm XLR male). Otherwise, use a termination plug as specified by the controller manual.
3. If using more than one lighting fixture with the controller, connect the data output on each fixture to the data input on the following fixture using XLR-XLR cables. The order in which you connect the fixtures is not important and has no influence on channel numbering - use an order which gives the easiest and shortest cable routing. To ensure proper transmission on the data link it is important to insert an XLR termination plug, as described above, in the last fixture on the link.
4. Use the DIP-switch to select the address on each fixture. If you are not familiar with this, see the section on address setting below. **Ensure that none of the RoboScans are set to stand-alone mode.** All fixtures should have pin 10 switched OFF.
5. Switch on and configure the controller. Apply power to the RoboScans. After a short start-up routine, they are ready for operation.
6. The RoboScans automatically detect which protocol, Martin or DMX, is being sent. (This function can be reactivated by switching ON all ten DIP-switches and then resetting the address.)

It is possible to insert non-Martin DMX fixtures with 5-pin XLR connections in the link. You will need a cable that adapts the 3-pin output on the Martin fixture to the 5-pin input on the non-Martin fixture. The cable connections are shown in the second table below. (The cable is available from Martin as P/N 11820002.)

**Cable Connections (P/N 11820003)
5-pin DMX Output to 3-pin Martin Input**

Description	5-pin male XLR	3-pin female XLR
Ground (screen)	pin 1	pin 1
(-) signal	pin 2	pin 3
(+) signal	pin 3	pin 2
Not used	pin 4	
Not used	pin 5	

**Cable Connections (P/N 11820002)
3-pin Martin output to 5-pin DMX Input**

Description	3-pin male XLR	5-pin female XLR
Ground (screen)	pin 1	pin 1
(-) signal	pin 3	pin 2
(+) signal	pin 2	pin 3
Not used		pin 4
Not used		pin 5

Focusing

With the RoboScan Pro 218 mounted in position, select a gobo and adjust the focus manually to produce a sharp image on the desired target.

Address setting

Besides setting stand-alone sequences, the DIP-switch is also used for setting the channel address on which the RoboScan Pro 218 responds to the controller. The Pro 218 uses 1 channel when operated via a Martin RS-485 protocol controller. It uses 6 channels when operated via a DMX-512 controller and DMX mode 1 is selected, and 8 channels when DMX mode 2 or 3 is selected. Please refer to the DMX table in appendix a.

The procedure for selecting DMX mode is described in the Maintenance section. The RoboScan Pro 218 is factory-set to DMX mode 3.

The address is selected by switching ON one or more of the 10 DIP-switch pins. Each ON pin adds the value listed in the following table. OFF pins add no value. The DIP-switch set-

ting can be found by subtracting pin values, starting from the highest pin value that is less than or equal to the channel address, until the total value of the pins equals the channel number. Pin 10 should always be switched OFF when setting an address.

Example 1: To set the address to channel 10, subtract 8 (pin 4) and 2 (pin 2), and set these pins ON.

Example 2: To set the address to channel 64, subtract 64 (pin 7) and set this pin ON.

Example 3: To set the address to channel 100, subtract 64 (pin 7), 32 (pin 6), and 4 (pin 3), and set these pins ON.

pin	1	2	3	4	5	6	7	8	9	10
value	1	2	4	8	16	32	64	128	256	Special

Dip-switch settings for all channels are listed in appendix b.

Operating with the 2308 or 2032 controller

Beginning with RoboScan Pro 218 software version 1.4, an improved speed array has been programmed for use with the Martin 2308 and 2032 controllers. This increases the range of speeds available for controlling effects. To use this feature, the DMX-mode jumper must be set to mode 3. **This is the factory default setting.** See section 7 for information on changing the jumper.

section 5

CONTROLLABLE FUNCTIONS

Pan/Tilt

The moving mirror allows you to pan the beam 175° and tilt it 85°. Microstep motors provide smooth and accurate movement at all speeds. DMX modes 1 and 2 offer 8-bit pan/tilt resolution, while DMX mode 3 and Martin mode provides finer position control with 16-bit resolution. Selecting the B/O speed blacks out the light while the mirror is moving.

Color wheel

The Pro 218 offers 18 color positions on the color wheel - 15 saturated dichroic colors, 2 multicolors, and open (white). The wheel can be positioned directly on any color, or, between two adjacent colors, thus splitting the beam into different colors. The acceleration control allows high-speed scrolling. Selecting B/O speed blacks out the light while scrolling at the highest speed.

Gobo wheel

The Pro 218 offers 17 different gobos plus open. The wheel can be positioned directly on any gobo, or, between two adjacent gobos, thus splitting the beam into different patterns. The acceleration control allows high-speed scrolling. Selecting B/O speed blacks out the light while scrolling at the highest speed.

Dimmer

Full-range dimming is provided via a motorized mechanical dimmer system. The dimmer speed is variable.

Shutter

The shutter allows you to switch the light on and off instantly and to create strobe effects. The strobe frequency is variable up to approximately 12 Hz.

section 6

MAINTENANCE

The RoboScan Pro 218 comes fully adjusted from the factory, however, some adjustments may be necessary for proper operation, particularly after changing the lamp, extensive use, or transportation to a new location.

IMPORTANT!

Read the procedures before making adjustments. If you are not experienced servicing electro-mechanical devices, please refer the work to a qualified technician.

Adjusting the Lamp

The RoboScan Pro 218 comes fully adjusted from the factory, however, readjustment of the lamp may be necessary due to differences between lamps. The lamp is adjusted by turning the 3 Phillips-head screws on the lamp access plate. Turning these clockwise pulls the lamp back towards the rear and vice versa. Keep adjustments small to avoid pulling the lamp so far off center that it hits the reflector.

NOTE: The lamp is not a hot-restrike type; you must wait approximately 10 minutes after having turned off the lamp before you can turn it back on again.

WARNING!

The fixture must be cool and disconnected from AC power.

1. Remove the 3 thumbscrews from the lamp access plate and remove the lamp assembly.
2. Make a preliminary adjustment: turn the adjustment screws so that the inside-to-inside measurement between the lamp socket mounting plate and the lamp access plate is 13 mm (1/2 in). Replace the lamp assembly.
3. Flip DIP-switch pins 8 and 10 on. Flip all other pins off.
4. Apply power to the RoboScan Pro 218. After it has reset, it produces a white light with an open gobo for adjustment purposes. Wait approximately 5 minutes for the lamp to reach full brightness.
5. Manually position the fixture and/or mirror so the light shines on a flat surface and focus the beam.
6. If there is an off-center "hot spot," the lamp is not centered in the reflector. "Pull" the hot spot into the center of the field with small adjustments of one or more of the screws.

7. If the light is significantly brighter in the center of the field than it is at the edge, the lamp is too far forward in the reflector. Pull the lamp in by turning all three screws clockwise 1/4-turn at a time until the light is evenly distributed.
8. If the light is brighter around the edge than it is in the center, or if light output is low, the lamp is too far back in the reflector. "Push" the lamp out by turning the screws counter-clockwise 1/4-turn at a time until the light is bright and evenly distributed.

DMX mode selection

Inside the RoboScan Pro 218 is a jumper for selecting the three DMX modes. Mode 3 (jumper on pins 4 and 5) is the factory-set default. Follow the procedure below to enable mode 1 or 2.

WARNING!

Disconnect the fixture from AC power before proceeding.

1. Release the 6 screws labelled 'D' and 'C' in figure 1 and carefully remove the complete pan/tilt section. Avoid unplugging the motor cables from the circuit board.
2. Locate the jumper labelled 'PL432' on the circuit board (refer to the nearby label). To enable mode 1, simply remove this jumper. To enable mode 2, move the jumper to pins 5 and 6.
3. Reassemble the fixture before connecting to AC power.

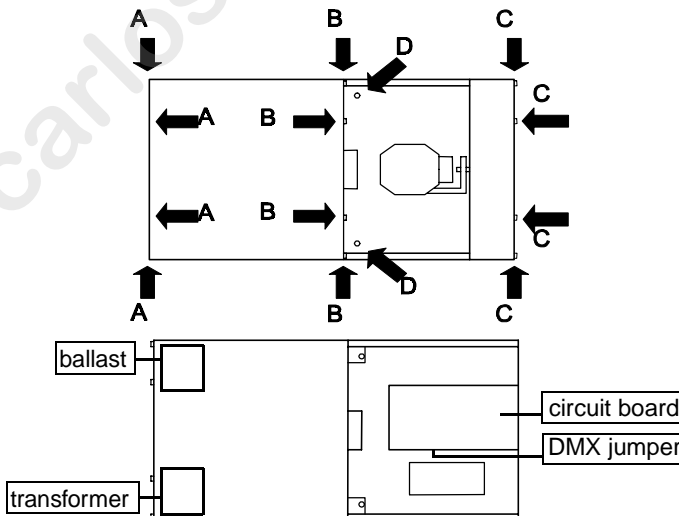

Figure 1

Selecting voltage and frequency

The RoboScan Pro 218 must be rewired if the voltage and frequency settings do not match the local AC power supply. The factory settings are printed on the label on the front of the fixture. The following table shows the available settings.

Model	Selectable Voltages	Selectable Frequencies
RoboScan Pro 218 EU	220 V / 230 V / 245 V	50 Hz
RoboScan Pro 218 US	100 V / 110 V / 120 V	50 Hz / 60 Hz
RoboScan Pro 218 US Arcstream	100 V / 110 V / 120 V	60 Hz

WARNING!

Disconnect the fixture from AC power before proceeding.

1. Unscrew the 8 screws, labelled 'A' and 'B' in figure 1, that secure the casing over the lamp housing and remove the casing.

ROBOSCAN PRO 218 US

2. Locate the ballast at the rear-left corner (see figure 1) and move the GREY wire, labelled 'F', to either the 50 Hz or the 60 Hz terminal to select the local frequency.
3. Similarly, locate the transformer at the rear-right corner of the unit, and move the BROWN wire, labelled 'V', to either the 100 V, 110 V, or 120 V terminal to select the local AC voltage.
4. Reassemble the unit before connecting to AC power.

ROBOSCAN PRO 218 EU

2. Locate the ballast at the rear-left corner (see figure 1) and move the GREY wire, labelled 'V', to either the 220 V, 230 V, or 245 V terminal to select the local AC voltage.
3. Locate the transformer at the rear-right corner of the unit and move the BROWN wire, also labelled 'V', to either the 225 V or 240 V terminal to select the local AC voltage.
4. Reassemble the unit before connecting to AC power.

ROBOSCAN PRO 218 US ARCSTREAM

2. Locate the transformer at the rear-right corner (see figure 1), and move the BROWN wire, labelled 'V', to either the 100 V, 110 V, or the 120 V terminal to select the local AC voltage.
3. Reassemble the unit before connecting to AC power.

Adjusting the mirror

Readjusting the mechanical stop on the RoboScan Pro 218 mirror adaptor is required if the pan or tilt motor occasionally loses step, leaving the mirror incorrectly positioned after a reset. This error occurs when the recoil of the mechanical reset bounces the mirror and bracket a whole pan or tilt motor step.

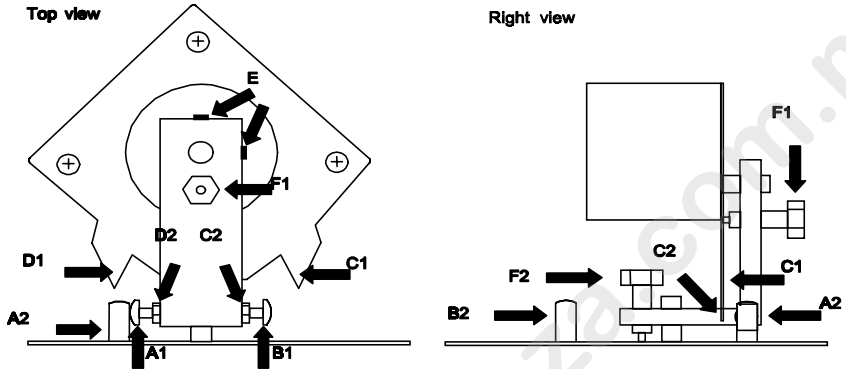

Figure 2

PAN ADJUSTMENT

1. Connect the RoboScan Pro 218 to a controller and set the address. Switch on the controller and then the RoboScan Pro 218.
2. Use the controller to move the mirror to the extreme left position, thus positioning screw A1 in figure 2 at the upper mechanical stop (A2).
3. Release the lock-nut on adjusting screw A1.
4. Turn screw A1 clockwise 1/2 - 1 turn to increase the distance between the head of the screw and the mechanical stop (A2).
5. Tighten the lock-nut on screw A1.
6. Reset the RoboScan Pro 218 a number of times to check the new reset position.
7. Use the controller to move the mirror through all extreme positions, checking that adjustment screw B1 does NOT touch the mechanical stop (B2) during these steps. If it does, then adjust screw B1 accordingly.

TILT ADJUSTMENT

1. Connect the RoboScan Pro 218 to a controller and set the address. Switch on the controller and then the RoboScan Pro 218.
2. Use the controller to move the mirror to the upper-left position until the top mechanical stop (C1 in figure 2) is positioned at the edge of the mirror bracket (C2).

3. Loosen the two allen-screws (E) holding the motor axle while taking care that the motor does not slide vertically from its current position.
4. Carefully turn the motor and mirror clockwise (make sure the motor axle does NOT turn) until there is a distance of 1/2 to 1 mm (1/64 - 1/32") between the edge of the mirror bracket (C2) and the top mechanical stop (C1).
5. Tighten the allen-screws.
6. Use the controller to reset the fixture and move the mirror through all extreme positions, checking that the bottom mechanical stop (D1) does NOT touch the edge of the mirror bracket (D2) during these steps. If it does, then readjust as described above, making the distance between C2 and C1 even smaller.

appendix a

DMX-512 PROTOCOL

The RoboScan Pro 218 supports tracking and vector mode and 8 and 16 bit pan/tilt resolution. The 3 DMX modes and the channel requirements for each are shown below. The correct mode will depend on your programming preferences and your controller's abilities.

In tracking mode, movement speed is determined directly by the controller's fade time.

In vector mode, speed is determined by a value programmed on a separate DMX channel. *For smooth movement in vector mode, the controller's fade time must be set to 0, i.e., the position must bump from the current value to the next.* If the RoboScan Pro 218 is set to run vector mode, tracking mode can be enabled by programming the speed channels to 0.

With 8-bit pan/tilt resolution, pan and tilt are divided into 256 positions. Finer position control is possible with 16-bit pan/tilt resolution, which divides each position into smaller increments.

DMX Setup	Channels	PL432 Jumper Location
Mode 1 - 8 bit Pan/Tilt Tracking	6	no jumper
Mode 2 - 8 bit Pan/Tilt Tracking/Vector	8	pin 5 and 6
Mode 3 - 16 bit Pan/Tilt Tracking	8	pin 4 and 5

DMX Protocol, All Modes

Channel	DMX Values	Effect
1	0 - 5	Shutter / Strobe / SA / Reset fixture Shutter Closed (Light off)
	6 - 80	Shutter Open (Light on)
	81 - 208	Strobe on (Fast → Slow)
	209 - 230	Remote Stand-alone auto trig
	231 - 252	Remote Stand-alone music trig
	253 - 255	Reset fixture
2	0 - 255	Dimmer Dimmer full ON (no light) → full OFF (Light)

DMX Protocol, All Modes

Channel	DMX Values	Effect
3	0 - 11	Color White → Flame Red
	11 - 22	Flame Red → Light Blue
	22 - 33	Light Blue → Frn. Green
	33 - 44	Frn. Green → Yellow
	44 - 55	Yellow → Primary Green
	55 - 66	Primary Green → Mauve
	66 - 77	Mauve → Dark Blue
	77 - 88	Dark Blue → Cyan Blue
	88 - 99	Cyan Blue → Primary Red
	99 - 110	Primary Red → Light Orange
	110 - 121	Light Orange → Light Green
	121 - 132	Light Green → Amber
	132 - 143	Amber → Pink
	143 - 154	Pink → D. Lavender
	154 - 165	D. Lavender → Dark Orange
	165 - 176	Dark Orange → Multicolor 1
	176 - 187	Multicolor 1 → Multicolor 2
	187 - 190	Multicolor 2
	191 - 193	Multicolor 1
	194 - 196	Dark Orange
	197 - 199	Dark Lavender
	200 - 202	Pink
	203 - 205	Amber
	206 - 208	Light Green
	209 - 211	Light Orange
	212 - 214	Primary Red
	215 - 217	Cyan Blue
	218 - 220	Dark Blue
	221 - 223	Mauve
	224 - 226	Primary Green
	227 - 229	Yellow
	230 - 232	Frn. Green
	233 - 235	Light Blue
	236 - 238	Flame Red
	239 - 255	White

DMX Protocol, All Modes

Channel	DMX Values	Effect
4	0 - 11	Gobo Open → Half
	11 - 22	Half → Dot
	22 - 33	Dot → Pin
	33 - 44	Pin → Vertical Bar
	44 - 55	Vertical Bar → Horizontal Bar
	55 - 66	Horizontal Bar → Cross
	66 - 77	Cross → Arrow
	77 - 88	Arrow → Triangles
	88 - 99	Triangles → Star
	99 - 110	Star → Holes
	110 - 121	Holes → Bells
	121 - 132	Bells → Cone
	132 - 143	Cone → Cones
	143 - 154	Cones → Phone
	154 - 165	Phone → Thin Bars
	165 - 176	Thin Bars → Window
	176 - 187	Window → Turbine
	187 - 190	Turbine
	191 - 193	Window
	194 - 196	Thin Bars
	197 - 199	Phone
	200 - 202	Cones
	203 - 205	Cone
	206 - 208	Bells
	209 - 211	Holes
	212 - 214	Star
	215 - 217	Triangles
	218 - 220	Arrow
	221 - 223	Cross
	224 - 226	Horizontal Bar
	227 - 229	Vertical Bar
	230 - 232	Pin
	233 - 235	Dot
	236 - 238	Half
	239 - 255	Open

DMX Protocol, MODES 1 and 2 ONLY

Channel	DMX Values	Effect
5	0 - 255	Pan Left → right (127 = neutral)
6	0 - 255	Tilt Up → down (127 = neutral)

DMX Protocol, MODE 2 ONLY

Channel	DMX Values	Effect
7	0 1 - 251 252 - 255	Speed: Pan / Tilt / Movement Tracking Speed, fast → slow Blackout while changing
8	0 - 251 252 - 255 0 - 251 252 - 255	Color / Gobo Speed Speed, fast → slow Black-out while changing Dimmer Speed Speed, fast → slow Speed, fast

DMX Protocol, MODE 3 ONLY

Channel	DMX Values	Effect
5	0 - 255	Pan Coarse (MSB) Left → right (127 = neutral)
6	0 - 255	Pan Fine (LSB) Left → right (127 = neutral)
7	0 - 255	Tilt Coarse (MSB) Up → down (127 = neutral)
8	0 - 255	Tilt Fine (LSB) Up → down (127 = neutral)

appendix b DIP-SWITCH TABLE

This table shows DIP-switch settings for channels 1- 511. To find a setting, locate the channel in the table. Follow the row to the left to find the settings for pins 1 through 5; follow the column to the top to find the settings for pins 6 through 9. A “0” indicates the pin is turned off and a “1” indicates the pin is turned on. *Pin 10 is always switched OFF when setting a controller address.*

Example: The table shows the setting for channel 212 is 00101 for pins 1 - 5 and 0110 for pins 6 - 9. Pins 3, 5, 7, and 8 are set to on; pins 1, 2, 4, 6, 9, and 10 are set to off.

DIP-Switch Setting					#9	0	0	0	0	0	0	0	0	1	1	1	1	1	1	1	1		
					#8	0	0	0	0	1	1	1	1	0	0	0	0	1	1	1	1	1	1
					#7	0	0	1	1	0	0	1	1	0	0	1	1	0	0	1	1	1	1
					#6	0	1	0	1	0	1	0	1	0	1	0	1	0	1	0	1	0	1
#1	#2	#3	#4	#5																			
0	0	0	0	0	32	64	96	128	160	192	224	256	288	320	352	384	416	448	480				
1	0	0	0	0	1	33	65	97	129	161	193	225	257	289	321	353	385	417	449	481			
0	1	0	0	0	2	34	66	98	130	162	194	226	258	290	322	354	386	418	450	482			
1	1	0	0	0	3	35	67	99	131	163	195	227	259	291	323	355	387	419	451	483			
0	0	1	0	0	4	36	68	100	132	164	196	228	260	292	324	356	388	420	452	484			
1	0	1	0	0	5	37	69	101	133	165	197	229	261	293	325	357	389	421	453	485			
0	1	1	0	0	6	38	70	102	134	166	198	230	262	294	326	358	390	422	454	486			
1	1	1	0	0	7	39	71	103	135	167	199	231	263	295	327	359	391	423	455	487			
0	0	0	1	0	8	40	72	104	136	168	200	232	264	296	328	360	392	424	456	488			
1	0	0	1	0	9	41	73	105	137	169	201	233	265	297	329	361	393	425	457	489			
0	1	0	1	0	10	42	74	106	138	170	202	234	266	298	330	362	394	426	458	490			
1	1	0	1	0	11	43	75	107	139	171	203	235	267	299	331	363	395	427	459	491			
0	0	1	1	0	12	44	76	108	140	172	204	236	268	300	332	364	396	428	460	492			
1	0	1	1	0	13	45	77	109	141	173	205	237	269	301	333	365	397	429	461	493			
0	1	1	1	0	14	46	78	110	142	174	206	238	270	302	334	366	398	430	462	494			
1	1	1	1	0	15	47	79	111	143	175	207	239	271	303	335	367	399	431	463	495			
0	0	0	0	1	16	48	80	112	144	176	208	240	272	304	336	368	400	432	464	496			
1	0	0	0	1	17	49	81	113	145	177	209	241	273	305	337	369	401	433	465	497			
0	1	0	0	1	18	50	82	114	146	178	210	242	274	306	338	370	402	434	466	498			
1	1	0	0	1	19	51	83	115	147	179	211	243	275	307	339	371	403	435	467	499			
0	0	1	0	1	20	52	84	116	148	180	212	244	276	308	340	372	404	436	468	500			
1	0	1	0	1	21	53	85	117	149	181	213	245	277	309	341	373	405	437	469	501			
0	1	1	0	1	22	54	86	118	150	182	214	246	278	310	342	374	406	438	470	502			
1	1	1	0	1	23	55	87	119	151	183	215	247	279	311	343	375	407	439	471	503			
0	0	0	1	1	24	56	88	120	152	184	216	248	280	312	344	376	408	440	472	504			
1	0	0	1	1	25	57	89	121	153	185	217	249	281	313	345	377	409	441	473	505			
0	1	0	1	1	26	58	90	122	154	186	218	250	282	314	346	378	410	442	474	506			
1	1	0	1	1	27	59	91	123	155	187	219	251	283	315	347	379	411	443	475	507			
0	0	1	1	1	28	60	92	124	156	188	220	252	284	316	348	380	412	444	476	508			
1	0	1	1	1	29	61	93	125	157	189	221	253	285	317	349	381	413	445	477	509			
0	1	1	1	1	30	62	94	126	158	190	222	254	286	318	350	382	414	446	478	510			
1	1	1	1	1	31	63	95	127	159	191	223	255	287	319	351	383	415	447	479	511			

appendix c

SPECIFICATIONS

DIMENSIONS

- Height without mounting bracket 185 mm (7.3")
- Height with mounting bracket 325 mm (12.6")
- Length 533 mm (22.0")
- Width 280 mm (11.1")
- Weight 14 kg (31 lb)

POWER AND CURRENT CONSUMPTION

- EU model 290 W, 1.3 A at 230 V / 50 Hz
- US model 290 W, 2.4 A at 120 V / 60 Hz
- US Arcstream model 220 W, 2.1 A at 120 V / 60 Hz

AC VOLTAGE AND FREQUENCY

- EU model 210 V to 260 V, 50 Hz
- US model 95 V to 125 V, 50 Hz / 60 Hz
- US Arcstream model 95 V to 125 V, 60 Hz

FUSE

- size, all models 5 x 20 mm
- EU model T (time delay) 3.15 A
- US model T (time delay) 6.30 A
- US Arcstream model T (time delay) 3.15 A

PHILIPS MSD 200 LAMP

- Martin P/N 97010106
- Wattage 200 W
- Color temperature 5600K
- Average life 2000 hrs

GE LIGHTING ARCSTREAM MBI150/T/40 LAMP

- Martin P/N 97010105
- Wattage 150 W
- Color temperature 4000K
- Average Life 6000 hrs

OPTICAL

- Beam angle: 11.5°
- Total luminous flux (w/MSD 200) 1250 lm

Martin Professional A/S
Olof Palmes Allé 18
DK-8200 Aarhus N, Denmark
Phone: +45 87 40 00 00
WWW: <http://www.martin.dk>