

# RUSH MH 10 Beam FX

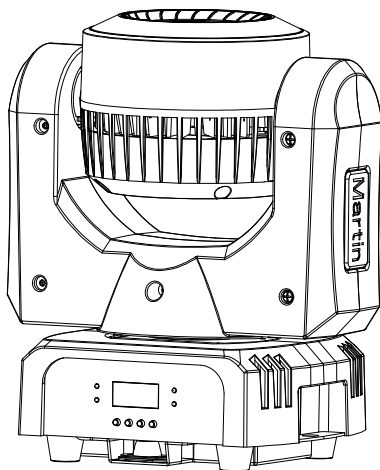

## User Manual

**Martin**<sup>®</sup>  
by HARMAN

# Table of contents

Safety information .....	5
Introduction .....	10
Before using the product for the first time .....	10
Physical installation .....	11
Fastening the fixture to a flat surface .....	11
Mounting the fixture on a truss .....	11
AC power .....	13
Linking fixtures to power in a chain .....	14
Fixture overview .....	15
Control data link .....	16
Tips for reliable data transmission .....	16
Connecting the data link .....	17
Fixture setup .....	18
Using the control menus .....	18
DMX addressing .....	18
DMX channel mode .....	19
Behavior without DMX (DMX State) .....	19
Stand-alone settings .....	19
Pan/tilt inversion .....	21
Dimmer settings .....	21
Backlight .....	22
Function delay .....	23
White balance adjustment .....	23
Manual test .....	23
Auto test .....	23
LED Temperature .....	24
Fixture time .....	24
Firmware version .....	24
Pro defaults .....	24
Reset .....	24
Fan mode .....	24
Home position adjustment (offset menu) .....	25
Setting options by RDM .....	25
Scanning for RDM devices on the data link .....	25
Getting status and setting options by RDM .....	26
RDM functions .....	26
Effects .....	28
Pan and tilt .....	28
Electronic dimming .....	29
Strobe effects .....	29
Colors .....	29

Maintenance .....	30
Cleaning .....	30
Replacing the primary fuse.....	31
Service and repairs .....	31
DMX protocol .....	32
Basic (24-channel) mode .....	32
Extended (93-channel) mode.....	37
Control menus.....	42
Troubleshooting .....	45
Specifications .....	46

[www.carlosmendoza.com.mx](http://www.carlosmendoza.com.mx)

# Safety information



## WARNING!

Read the safety precautions in this manual before installing, operating or servicing this product.

The following symbols are used to identify important safety information on the product and in this manual:



**Warning!**

**Safety hazard. Risk of severe injury or death.**



**Warning!**

**Powerful light emission. Risk of eye injury.**



**Warning!**

**See user manual for important safety information.**



**Warning!**

**Hazardous voltage. Risk of lethal or severe electric shock.**



**Warning!**

**Hot surfaces.**



**Warning!**

**Fire hazard.**



Warning! Risk Group 2 product according to EN 62471. Possibly hazardous radiation emitted from this product. May be harmful to the eyes. Do not stare at operating lamp and do not view the light output with optical instruments or any device that may concentrate the beam.

This lighting fixture is for professional use only and must be installed by a qualified technician. It is not for household use. It presents risks of severe injury or death due to fire hazards, electric shock and falls. It produces a powerful, concentrated beam of light that can create a fire hazard or a risk of eye injury if the safety precautions below are not followed.



Install, operate and service Martin® products only as directed in their user manuals, or you may create a safety hazard or cause damage that is not covered by product warranties.

Follow the safety precautions listed below and observe all warnings in this manual and printed on the product. Keep this user manual for future use.

For the latest user documentation and other information for this and all Martin® products, please visit the Martin website at <http://www.martin.com>

If you have any questions about how to install, operate or service the fixture safely, please contact your Martin® distributor (see [www.martin.com/where-to](http://www.martin.com/where-to) for details) or call the Martin® 24-hour service hotline on +45 8740 0000, or in the USA on 1-888-tech-180.

Respect all locally applicable laws, codes and regulations when installing, operating or servicing the fixture.



### **Protection from electric shock**

Do not expose the fixture to rain or moisture.

Disconnect the fixture from AC power before carrying out any installation or maintenance work and when the fixture is not in use.

Ensure that the fixture is electrically connected to ground (earth).

Use only a source of AC power that complies with local building and electrical codes and has both overload and ground-fault (earth-fault) protection.

Socket outlets or external power switches used to supply the fixture with power must be located near the fixture and easily accessible so that the fixture can easily be disconnected from power.

Replace defective fuses with ones of the specified type and rating only.

Isolate the fixture from power immediately if the power plug or any seal, cover, cable, or other component is damaged, defective, deformed, wet or showing signs of overheating. Do not reapply power until repairs have been completed

Before using the fixture, check that all power distribution equipment and cables are in perfect condition and rated for the electrical requirements of all connected devices.

The mains power input cable supplied with the fixture is rated 6 A and can supply only one fixture with mains power. Do not connect any device to the fixture's MAINS OUT socket when using this input cable. If you want to connect other fixtures to

the MAINS OUT socket, see 'Linking fixtures to power in a chain' on page 14.



### **Protection from burns and fire**

Do not operate the fixture if the ambient temperature ( $T_a$ ) exceeds  $40^\circ\text{C}$  ( $104^\circ\text{F}$ ).



The surface of the product casing can reach up to  $50^\circ\text{C}$  ( $122^\circ\text{F}$ ) during operation. Avoid contact by persons and materials. Allow the fixture to cool for at least 10 minutes before handling.

Keep flammable materials well away from the fixture. Keep all combustible materials (e.g. fabric, wood, paper) at least 100 mm (4 in.) away from the fixture head.

Ensure that there is free and unobstructed airflow around the fixture. Provide a minimum clearance of 100 mm (4 in.) around fans and air vents.

Do not illuminate surfaces within 200 mm (8 in.) of the fixture.

Do not attempt to bypass thermostatic switches or fuses.

Do not stick filters, masks or other materials onto any optical component.

The fixture's lenses can focus the sun's rays inside the fixture, creating a risk of fire and damage. Do not expose the front of the fixture to sunlight or any other bright light source.



### **Protection from eye injury**

The fixture falls into Risk Group 2 according to EN62471. To minimize the risk of eye irritation or injury, disconnect the fixture from power at all times when the fixture is not in use, and provide well-lit conditions to reduce the pupil diameter of anyone working on or near the fixture.

The light from the LED lamp is possibly hazardous and may be harmful to the eyes. Do not stare directly into the product's light output.

Do not look at the light output with magnifiers, telescopes, binoculars or similar optical instruments that may concentrate the light output.

Ensure that persons are not looking directly into the LEDs when the product lights up suddenly. This can happen when power is

applied, when the product receives a DMX signal, or when certain control menu items are selected.

The fixture falls into the following Risk Groups according to EN62471 at the distances indicated below:

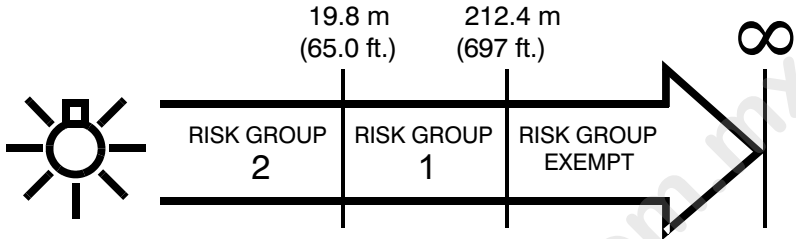

### Protection from injury

Fasten the fixture securely to a fixed surface or structure when in use. The fixture is not portable when installed.

Ensure that any supporting structure and/or hardware used can hold at least 10 times the weight of all the devices they support.

If suspending from a rigging structure, fasten the fixture to a rigging clamp. Do not use safety cables as the primary means of support.

If the fixture is installed in a location where it may cause injury or damage if it falls, install as directed in this manual a secondary attachment such as a safety cable that will hold the fixture if a primary attachment fails. The secondary attachment must be approved by an official body such as TÜV as a safety attachment for the weight that it secures, must comply with EN 60598-2-17 Section 17.6.6 and must be capable of bearing a static suspended load that is ten times the weight of the fixture and all installed accessories.

Allow enough clearance around the head to ensure that it cannot collide with an object or another fixture when it moves.

Check that all external covers and rigging hardware are securely fastened.

Block access below the work area and work from a stable platform whenever installing, servicing or moving the fixture.

Do not operate the fixture with missing or damaged covers, shields or any optical component.

Do not lift or carry the fixture by its head. Support the fixture by its base only.

In the event of an operating problem, stop using the fixture immediately and disconnect it from power. Do not attempt to use a fixture that is obviously damaged.

Do not modify the fixture in any way not described in this manual or install other than genuine Martin® parts.

Refer any service operation not described in this manual to a qualified technician.

[www.carlosmendoza.com.mx](http://www.carlosmendoza.com.mx)



# Introduction

The RUSH™ MH 10 Beam FX is a fast, compact moving head effect fixture with dual LED effects: a 60W long-life RGBW LED providing an intense 4.4 degree beam effect and an array of 24 smaller LEDs providing a background ring of light with full individual pixel control and built-in animation effects. The pan and tilt can continuously rotate 360 degrees or provide fixed 16-bit positioning and the fixture also features smooth electronic dimming and strobe effects. The rugged, lightweight construction makes it ideal for events, touring, and small venues.

The fixture is supplied with this user manual, a 1.5 m (4.9 ft.) bare-ended power cable ready for a local power plug (not included) and a mounting bracket for attachment of a suitable, user-supplied rigging clamp.

## Before using the product for the first time

1. Read 'Safety information' starting on page 5 before installing, operating or servicing the fixture.
2. Unpack and ensure that there is no transportation damage before using the fixture. Do not attempt to operate a damaged fixture.
3. If the fixture is not going to be hard-wired to a mains supply, install a local power plug (not supplied) to the end of the supplied power cable.
4. Before operating, ensure that the voltage and frequency of the power supply match the power requirements of the fixture.
5. Check the support pages on the Martin Professional website at [www.martin.com](http://www.martin.com) for the most recent user documentation and technical information about the fixture. Martin® user manual revisions are identified by the revision letter at the bottom of the inside cover.

Note that whenever AC power is applied to the fixture, it will reset all effects and functions to their home positions. Be prepared for the fixture head to move. A reset usually takes around 20 seconds.

## Physical installation



**Warning! Read 'Safety information' on page 5 before installing the fixture.**

The fixture is designed for indoor use only and must be used in a dry location with adequate ventilation. Ensure that none of the fixture's ventilation slots are blocked and all minimum distances are observed.

The fixture must be installed by a qualified technician. It may be operated in any orientation.

Fasten the fixture to a secure structure or surface. Do not stand it on a surface or leave it where it can be moved or fall over. If you install the fixture in a location where it may cause injury or damage if it falls, secure it as directed in this user manual using a securely anchored safety cable that will hold the fixture if the primary fastening method fails.

Martin® can supply safety cables and rigging clamps that are suitable for use with the fixture (see 'Accessories' on page 48).

### Fastening the fixture to a flat surface

The fixture can be fastened to a hard, fixed, flat surface in any orientation. Ensure that the surface and all fasteners used can support at least 10 times the weight of all fixtures and equipment they will support.

Fasten the fixture securely. Do not stand it on a surface or leave it where it can be moved or fall over. If you install the fixture in a location where it may cause injury or damage if it falls, secure it as directed below with a securely anchored safety cable that will hold the fixture if the primary fastening method fails.

### Mounting the fixture on a truss

The fixture can be clamped to a truss or similar rigging structure in any orientation. Use a suitable rigging clamp such as a G-clamp or a half-coupler clamp (see illustration on right) fastened to the included omega bracket.



To clamp the fixture to a truss:

1. Check that the rigging structure can support at least 10 times the weight of all fixtures and equipment to be installed on it.
2. Block access under the work area.

3. The fixture is supplied with an omega-type bracket to which a rigging clamp can be attached. Bolt a rigging clamp securely to the bracket. The bolt used must be M12, grade 8.8 steel minimum, and fastened with a self-locking nut.

4. Fasten the omega bracket to mounting holes **A** on the base of the fixture using the bracket's quarter-turn fasteners. Turn quarter-turn fasteners a full 90° to lock them (see illustration on right).

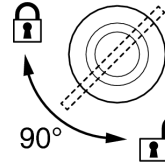

5. Working from a stable platform, hang the fixture vertically on the truss and fasten the rigging clamp onto the truss.

6. Secure the fixture with a safety cable through attachment points **B** as directed below.

7. Check that the head will not collide with other fixtures or objects.

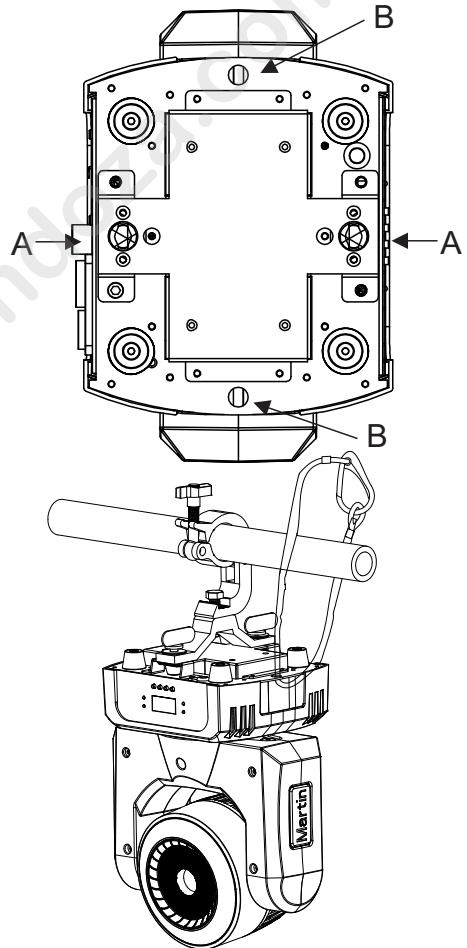

### Securing with a safety cable

Secure the fixture with a safety cable (or other secondary attachment) that is approved for the weight of the fixture so that the safety cable will hold the fixture if the primary attachment fails. Loop the safety cable through one of the two attachment points **B** in the base of the fixture base (see illustrations above and to right) and around a secure anchoring point.

If a safety cable attachment point becomes damaged or deformed, do not use the fixture. Return it to a Martin Service Centre for repair.

## AC power



**Warning!** Read ‘Safety information’ on page 5 before connecting the fixture to AC mains power.



**Warning!** The mains power input cable supplied with the fixture is rated 6 A and can supply only one fixture with mains power. Do not connect any device to the fixture’s MAINS OUT socket when using this input cable. If you want to connect other fixtures to the MAINS OUT socket, see ‘Linking fixtures to power in a chain’ on page 14.

For protection from electric shock, the fixture must be grounded (earthed). The power distribution circuit must be equipped with a fuse or circuit breaker and ground-fault (earth-fault) protection.

Socket outlets or external power switches used to supply the fixture with power must be located near the fixture and easily accessible so that the fixtures can easily be disconnected from power.

Do not use an external dimming system to supply power to the fixture, as this may cause damage to the fixture that is not covered by the product warranty.

The fixture can be hard-wired to a building electrical installation if you want to install it permanently, or a power plug (not supplied) that is suitable for the local power outlets can be installed on the power cable. Socket outlets or external power switches used to supply the fixture with power must be located near the fixture and easily accessible so that the fixture can easily be disconnected from power.

If you install a power plug on the supplied power cable, install a grounding type (earthed) plug with integral cable grip that is rated 8 A minimum, 250 V. Follow the plug manufacturer’s instructions and connect the wires in the power cable as shown in this table:

	Live or L	Neutral or N	Earth, Ground or 
<b>US system</b>	Black	White	Green
<b>EU system</b>	Brown	Blue	Yellow/green

The fixture has an auto-ranging power supply that accepts AC mains power at 100-240 V at 50/60 Hz. Do not apply AC mains power at any other voltage or frequency to the fixture.

## Linking fixtures to power in a chain

The mains power input cable supplied with the fixture is rated 6 A and can safely supply enough power for one fixture only. If you want to use the MAINS OUT socket on the fixture to link power to another fixture in a daisy-chain, you must obtain the larger power input cables and power link cables available as an accessory from Martin (see 'Accessories' on page 48).

Using the 14 AWG or 1.5mm<sup>2</sup> cables from Martin®, you can link:

- Maximum nine (9) MH 10 fixtures in total at 100-120 V, or
- Maximum nineteen (19) MH 10 fixtures in total at 200-240 V.

If you install a power plug on the 14 AWG / 1.5 mm<sup>2</sup> power input cable, install a grounding type (earthed) plug with integral cable grip that is rated 16 A minimum, 250 V.

# Fixture overview

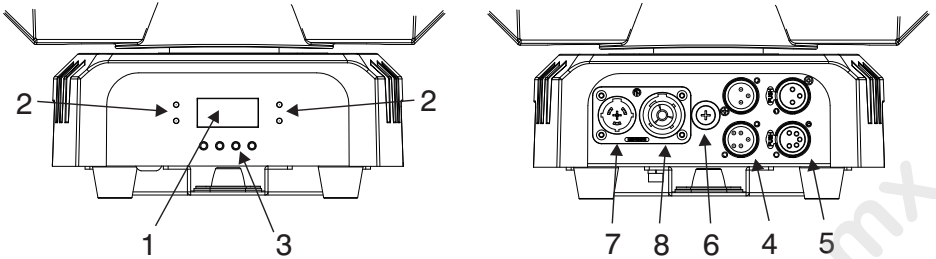

## 1 – Display

## 2 – LEDs

Four LEDs provide status information.

- DMX: Valid DMX signal present.
- SLAVE: Fixture operating as a stand-alone slave.
- MASTER: Fixture operating as the stand-alone master.
- SOUND: Audio signal triggering stand-alone sequence.

## 3 – Control buttons

- MENU: Press to activate the menu. Within the menu, press to escape and return to the previous level. Press and hold to exit the menu.
- DOWN: Press to scroll down through menu options.
- UP: Press to scroll up through menu options.
- ENTER: Press to confirm and save the menu selection.

## 4, 5 – XLR DMX input/output

For your convenience, 3 and 5-pin XLR sockets are provided for DMX input and output (through to next fixture). Do not connect output cables to both the 3-pin and 5-pin output sockets at the same time as this may cause data errors (in other words, you cannot use the two outputs on the fixture to split the DMX line).

## 6 – Fuse

The T 2.0 A fixture fuse is located in a fuseholder next to the power input/output connectors.

## 7 – AC mains power input

A yellow Neutrik True1 powerCON inlet connector is provided to connect the fixture to mains power.

## 8 – AC mains power link output

A yellow Neutrik True1 powerCON outlet connector is provided to allow mains power to be linked to the next fixture. Please refer to the section above “Linking fixtures to power in a chain” for safe use of this connector.

## Control data link

A DMX 512 data link is required in order to control the fixture via DMX. The fixture has 3-pin and 5-pin XLR connectors for DMX data input and output.

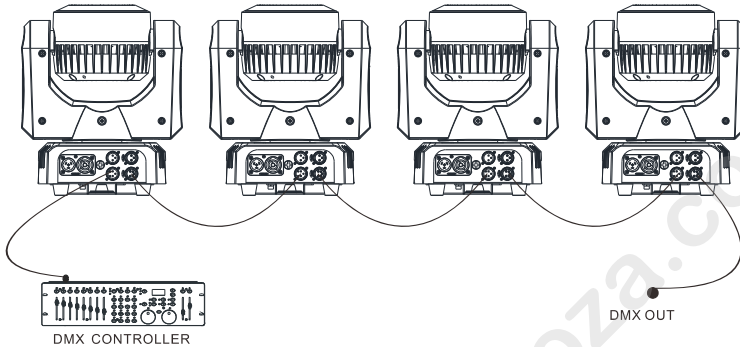

Up to 32 devices can be linked together on a single daisy chain. The total number of fixtures in one 512-channel DMX universe is limited by the number of DMX channels required by the fixtures. Note that if independent control of a fixture is required, it must have its own DMX channels. Fixtures that are required to behave identically can share the same DMX address and channels. To add more fixtures or groups of fixtures when the above limits are reached, add a DMX universe and/or split the daisy-chained link into branches using a powered DMX splitter.

## Tips for reliable data transmission

Use shielded twisted-pair cable designed for RS-485 devices: standard microphone cable cannot transmit control data reliably over long runs. 24 AWG cable is suitable for runs up to 300 meters (1000 ft.). Heavier gauge cable and/or a DMX buffer is recommended for longer runs. The pin-out on all connectors is:

- pin 1 = shield
- pin 2 = cold (-)
- pin 3 = hot (+).

Pins 4 and 5 in the 5-pin XLR connectors are not used in the fixture but are available for possible additional data signals as required by the DMX512-A standard. Standard pin-out is pin 4 = data 2 cold (-) and pin 5 = data 2 hot (+).

To split the link into branches, use an opto-isolated splitter such as the Martin® DMX 5.3 Splitter. Terminate the link by installing a termination plug in the output socket of the last fixture. The termination plug, which is a male XLR plug with a 120 Ohm, 0.25 W resistor soldered between pins 2 and 3, “soaks up” the control signal so it does not reflect and cause interference. If a splitter is used, terminate each branch of the link.

## **Connecting the data link**

To connect the fixture to data:

1. Connect the DMX data output from the controller to the closest fixture’s male XLR DMX input connector.
2. Connect the first fixture’s DMX output to the DMX input of the next fixture and continue connecting fixtures output to input. Terminate the last fixture on the link with a DMX termination plug.



## Fixture setup

This section explains the fixture characteristics you can set that determine how it can be controlled and will behave. You choose the settings using the menus available from the control panel, and they are retained even when the fixture is powered off.

You can also set the options on the fixture remotely over the DMX line using a suitable RDM controller.

A complete map of the control menu structure and brief explanations of their purposes can be found on page 32.

## Using the control menus

To access the control menus, press the MENU button. Navigate the menu structure using the ENTER, DOWN and UP buttons. To select a menu option or to confirm a selection, press the ENTER button. To return to a higher level in the menu structure without making a change, press the MENU button.

To exit the control menus completely, press and hold the MENU button.

## DMX addressing

The DMX address, also known as the start channel, is the first channel used to receive instructions from a DMX controller. The fixture is controlled using a minimum of 24 DMX channels (but has an extended mode which uses more channels). Each DMX controlled fixture must have a DMX address set. For example, if the fixture has a DMX address of 10, then it uses channels 10 to 33 inclusive. The following fixture in the DMX chain could then be set to a DMX address of 35.

For independent control, each fixture must be assigned its own control channels. Two fixtures of the same type may share the same address if identical behavior is desired. Address sharing can be useful for diagnostic purposes and symmetric control, particularly when combined with the inverse pan and tilt options.

To set the fixture's DMX address:

1. In the control menu, select DMX ADDRESS and press ENTER to confirm. The present address will blink in the display.
2. Use the UP and DOWN buttons to select an address from 1 to 492 (the top address will vary depending on the DMX mode of the fixture).
3. Press ENTER to confirm your selection.

## DMX channel mode

You can control the fixture in two modes:

Basic (24 channel mode) controls all 24 cells of the LED ring together, so they will be all the same color in RGB mode (though FX animations for the ring are provided).

Extended (93 channel mode) allows you to control the 24 cells of the LED ring separately using 24 groups of RGB control.

See “DMX protocol” on page 32 for a table showing the function of each DMX channel.

To adjust the setting:

1. Select CHANNEL MODE and press ENTER. The currently set option will blink in the display.
2. Use the DOWN and UP buttons to select Basic 24ch (default) or Extended 93ch.
3. Press ENTER to save your selection.

## Behavior without DMX (DMX State)

The DMX STATE setting determines how the fixture behaves when it is not receiving a DMX signal. You can set the fixture to enter Show Mode, black out, or hold the effect it was displaying when the DMX signal stopped. The fixture is set to HOLD by default.

To adjust the setting:

1. Select DMX STATE and press ENTER. The currently set option will blink in the display.
2. Use the DOWN and UP buttons to select SHOW MODE (fixture enters Show Mode), BLACKOUT (fixture blacks out) or HOLD (fixture shows the last effect it was displaying before the DMX signal stopped).
3. Press ENTER to save your selection.

## Stand-alone settings

The fixture will operate in stand-alone mode if it is not receiving a DMX signal and the DMX STATE menu option is set to SHOW MODE (see above), or if you enter the SHOW MODE menu in the control panel.

### ***Stand-alone show selection (Show Mode)***

Four pre-programmed stand-alone shows are available. To set the show that the fixture will run in Show Mode:

1. Select SHOW MODE and press ENTER to confirm. The currently selected show will blink in the display.
2. Use the DOWN and UP buttons to select Show 1, 2, 3 or 4.
3. Press ENTER to save your selection.

### ***Master/slave operation***

Fixtures in Show Mode can be linked in a chain and set to master/slave operation, where one master fixture running a standalone show controls the behavior of slave fixtures. Two slave modes are available:

- Fixtures in Slave 1 mode copy the master.
- Fixtures in Slave 2 mode are synchronized with the master but have slight variations in behavior.

You must set all the fixtures except one as slaves. If you set more than one fixture in the chain to act as master, you may cause damage that is not covered by the product warranty.

To operate fixtures in master/slave mode:

1. Link fixtures in a chain, using DMX cable to connect one fixture's DMX OUT socket to the next fixture's DMX IN socket. See 'Control data link' on page 16.
2. In the MASTER SLAVE menu, set one fixture to MASTER and set all the other fixtures to SLAVE 1 or SLAVE 2.
3. Set the master fixture in the chain to run one of its four standalone shows using its SHOW MODE menu (see 'Show Mode' above).
4. Set all the fixtures in the chain to DMX STATE → SHOW MODE.
5. Make sure that the fixtures are not receiving a DMX signal.

### ***Sound activation in show mode***

Show Mode can be combined with sound activation. The fixture has a built-in microphone that can be used to trigger scene changes in sync with a music beat (music rig) when the fixture is running in Show Mode.

To enable sound activation:

1. Select SOUND MODE and press ENTER.
2. Use the DOWN and UP buttons to select ON (sound activation enabled) or OFF (sound activation disabled).
3. Press ENTER to save your selection.

To adjust the sensitivity of sound activation to the volume of the music:

1. Turn on the music source and set it to the desired volume.
2. Select SOUND SENSE and press ENTER.

3. Use the DOWN and UP buttons to change the sensitivity level from 0 to 100.
4. When the fixture responds correctly to the beat, press ENTER to save your selection.

## **Pan/tilt inversion**

The PAN INVERSE and TILT INVERSE menus can be used to reverse the direction of pan and tilt. These settings are useful for symmetrical effects with multiple fixtures, or when coordinating the movement of fixtures that are floor mounted and rigged upside down.

To adjust the pan inversion settings:

1. Select PAN INVERSE and press ENTER to confirm. The currently set mode will blink in the display.
2. Use the DOWN and UP buttons to select YES (tilt inversion) or NO (normal) mode.
3. Press ENTER to save your selection.

To adjust the tilt inversion settings:

1. Select TILT INVERSE and press ENTER to confirm. The currently set mode will blink in the display.
2. Use the DOWN and UP buttons to select YES (tilt inversion) or NO (normal) mode.
3. Press ENTER to save your selection.

## **Dimmer settings**

### ***Dimming curve***

Four dimming curves are available to modify dimmer response. The default is MODE 2. The settings affect response as follows:

- MODE 1    LINEAR: the increase in light intensity appears to be linear as DMX value is increased.
- MODE 2    SQUARE LAW: light intensity control is finer at low levels and coarser at high levels.
- MODE 3    INVERSE SQUARE LAW: light intensity control is coarser at low levels and finer at high levels.
- MODE 4    S-CURVE: light intensity control is finer at low levels and high levels and coarser at medium levels.

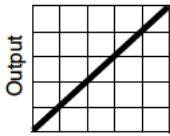

DMX %  
Output  
**Optically linear**

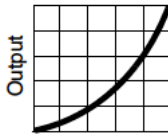

DMX %  
Output  
**Square law**

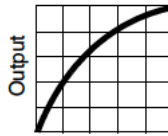

DMX %  
Output  
**Inverse square law**

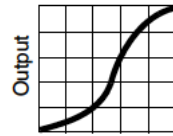

DMX %  
Output  
**S-curve**

To set the fixture's dimmer curve:

1. Select DIMMER CURVE and press ENTER to confirm. The mode that is currently active will blink in the display.
2. Use the DOWN and UP buttons to select the desired mode.
3. Press ENTER to save your selection.

Dimming curve can also be set by DMX using the Special Function channel.

### ***Dimmer speed***

There are two dimmer speed options:

- SNAP is the default setting. It sets the dimmer to exactly follow changes in dimming level sent from the controller. This gives the fastest dimmer response.
- FADE adds an approximate two-second smooth fade to changes in dimming level sent from the controller. This gives the smoothest dimmer fading.

To set the dimmer speed:

1. Select DIMMER SPEED and press ENTER to confirm.
2. Use the DOWN and UP buttons to select SNAP or FADE. Press ENTER to confirm.

### **Backlight**

To turn the control panel display backlight on or off:

1. Select BACK LIGHT and press ENTER to confirm. The current mode will blink in the display.
2. Use the DOWN and UP buttons to select ON or OFF.
3. Press ENTER to save your selection.

The backlight can also be turned on or off by DMX using the Special Function channel.

## Function delay

To reduce the risk of accidental activation, you can set a delay of up to 3 seconds before a DMX command will activate a function on the special function settings DMX channel. To set the delay duration:

1. Select FUNCTION DELAY and press ENTER to confirm. The current delay setting will blink in the display.
2. Use the DOWN and UP buttons to select No Delay, 1S Delay, 2S Delay or 3S Delay (default).
3. Press ENTER to save your selection (or press MENU to exit without saving any changes).

## White balance adjustment

As LED brightness changes with age, you may want to adjust the output of the fixture to match the color of other fixtures. You can individually adjust the brightness of the red, green and blue emitters to produce the desired white color. To adjust the fixture's white balance:

1. Select WHITE BALANCE and press ENTER to confirm.
2. Use the DOWN and UP buttons to select RED, GREEN or BLUE.
3. Once the color has been selected, press ENTER.
4. Use the DOWN and UP buttons to adjust the amount of that color (125~255) in the white balance mix.
5. Press ENTER to save your selection (or press MENU to exit without saving any changes).

## Manual test

Fixture functions can be individually controlled and tested manually. This feature can be also used to setup a static scene without a controller. To operate the fixture effects manually:

1. Select Manual Test and press ENTER.
2. Use the DOWN and UP buttons to select the function you want to set.
3. Once the function has been selected, press ENTER.
4. Use the DOWN and UP button to change the value (0-255).
5. Press MENU to exit.

## Auto test

To perform a complete test of all of the fixture functions:

1. Select AUTO TEST and press the ENTER button.

2. Press the ENTER button. The fixture will run a self-test routine.

## LED Temperature

To check the LED Temperature of the fixture, select LED TEMP. and press ENTER. The display will show the temperature of the unit. Press MENU to exit.

## Fixture time

To display the fixture's operating hours counter, select FIXTURE TIME and press ENTER. The display will show the number of hours the fixture has been in operation since manufacture. Press MENU to exit.

## Firmware version

To display the fixture's current firmware version, select FIRMWARE VERSION and press ENTER. The display will show the version of firmware in the fixture. Press MENU to exit.

## Pro defaults

PRO Defaults lets you cancel any changes in fixture settings that have been made using the control panel and return the fixture to its original factory default settings. To restore the default settings:

1. Select PRO DEFAULTS and press ENTER. The display will blink.
2. Use the DOWN and UP buttons to select YES.
3. Press ENTER to restore the default settings (or press MENU to exit without making any changes).

## Reset

The fixture resets its motors each time you power it on, but you can also reset the fixture motors manually from the control panel and by DMX. To carry out a manual reset from the control panel, scroll to RESET and press ENTER to reset the fixture, or press MENU to exit without resetting. A reset takes approx. 20 seconds. After this, the fixture returns to its state before the reset.

The fixture motors can also be reset by DMX using the Special Function channel.

## Fan mode

Fan speed can be adjusted to maximize light output or quiet operation.

1. Select FAN MODE and press ENTER.
2. Using the DOWN and UP buttons, toggle between the two modes:

- LOW. Fans run at constant low speed for quieter operation. Light output is reduced when necessary to control fixture temperature.
  - AUTO. Fan speed increases when necessary to control fixture temperature, but light output is constant.
3. Press ENTER to confirm your choice.

## Home position adjustment (offset menu)

If the fixture head does not return to the correct home position even after a reset, you can adjust the home position by defining offsets.

To make the adjustment from the control panel:

1. Reset the fixture motors as described above.
2. While still in menu mode, press and hold ENTER for at least 3 seconds to enter Offset mode.
3. Use the DOWN and UP buttons up to choose PAN or TILT function to adjust.
4. Use the DOWN and UP buttons to adjust the effect's home position.
5. Press ENTER to save your selection (or press MENU to exit without saving any changes).

The fixture offset/calibration can also be set by DMX using the Special Function channel.

## Setting options by RDM

You can remotely configure the fixture over the DMX line using RDM. Martin® offers a range of suitable RDM-compatible controllers.

Martin® M-PC is a Windows-based application available from Martin® that lets you set up, manage and control a lighting installation from a PC that is connected to the installation via a DMX data link. To use Martin® M-PC, connect a PC running the application to the data link via a USB-to-DMX interface box such as the Martin® M-DMX.

A full list of the RDM functions that the MH 10 fixture supports is given at the end of this chapter. These functions are generally referred to using the more specific term 'PIDs' or 'Parameter IDs'.

## Scanning for RDM devices on the data link

Before you can communicate with fixtures using RDM, you must send a scan command (also called a device discovery command) to all the devices on the data link so that the RDM controller can identify them. It does this by retrieving



each device's factory-set unique identifier (UID). This process can take some time depending on the number of devices on the link.

To identify the fixtures on the link:

Check that the fixtures are correctly connected to the RDM controller on the data link and that power is applied to all fixtures.

1. In Martin® M-PC, go to RDM CONTROLLER → DISCOVER DEVICES.
2. Give the controller time to identify the devices on the link and prepare for communication with the devices.

## Getting status and setting options by RDM

The status and options listed in the table below can be read and set by RDM.

You can set an option on one fixture by sending a unicast RDM command to that one fixture only, or you can set the same option on all the fixtures on the data link by sending a broadcast RDM command to all the devices on the link.

For status reading, you can only use unicast RDM to read information from an individual fixture.

## RDM functions

As a minimum, MH 10 supports the following RDM functions:

### *Device discovery*

DISC_UNIQUE_BRANCH
DISC_MUTE
DISC_UN_MUTE

### *Device management*

	GET	SET
DEVICE_INFO	✓	
IDENTIFY_DEVICE	✓	✓
DMX_START_ADDRESS	✓	✓
SOFTWARE_VERSION_LABEL	✓	
SUPPORTED_PARAMETERS	✓	
RESET_DEVICE		✓

COMMS_STATUS	✓	
QUEUED_MESSAGE	✓	
STATUS_MESSAGES	✓	
STATUS_ID_DESCRIPTION	✓	
CLEAR_STATUS_ID		✓
DEVICE_MODEL_DESCRIPTION	✓	
MANUFACTURER_LABEL	✓	
DEVICE_LABEL	✓	✓
BOOT_SOFTWARE_VERSION_ID	✓	
DMX_PERSONALITY	✓	✓
DMX_PERSONALITY_DESCRIPTION	✓	
SENSOR_DEFINITION	✓	
SENSOR_VALUE	✓	
DEVICE_HOURS	✓	
PAN_INVERT	✓	✓
TILT_INVERT	✓	✓
LAST_STATE (0XA004)*		✓
DIMMER_CURVE (0XA007)*		✓

\*See 'Control menus' on page 42 for an explanation of this function.

## Effects

See 'DMX protocol' on page 32 for a full list of the DMX channels and values required to control the different effects.

### Pan and tilt

The fixture's head can be rotated continuously on both pan and tilt axes, or can be positioned through 540° of pan and 270° of tilt with 16-bit coarse and fine control. Using the control menus it is possible to invert pan or tilt movement.

To set fixed positions for pan or tilt, ensure that the corresponding Rotation control channel is set to zero.

The fixture incorporates pan and tilt feedback, so that if a pan or tilt position error is detected or the fixture is knocked out of position, the shutter closes and the fixture resets to the correct pan & tilt position.

#### ***Pan/tilt options***

Using the Special Function control channel (ch15) you can configure various pan/tilt options. Return the Special Function channel to zero to resume normal DMX control. If a delay time is set in the "Function Delay" setting then you need to add this time to the time below.

**Auto-blackout:** Light output will be blacked out when the head moves.

- On: hold Special Function between 145-149 for 1 second.
- Off (default): hold Special Function between 150-154 for 1 second.

**Pan-Tilt speed:** Sets the maximum speed for pan-tilt.

- Fast (default): hold Special Function between 80-84 for 1 second.
- Smooth: hold Special Function between 85-89 for 1 second.

**Adjust Pan-Tilt home position (calibration):** follow this sequence.

1. Hold Special Function channel between 55-59 for 5 seconds.
2. Set desired Pan and/or Tilt position using the pan/tilt DMX channels.
3. Hold Special Function channel between 165-169 for 5 seconds to store the settings.
4. Return Special Function channel to zero.

**Reset Pan-Tilt home position to factory default:** hold Special Function channel between 245-249 for 5 seconds.

## Electronic dimming

You can set the overall intensity of the beam effect and the ring effect separately using electronic dimming from 0 to 100%. There is 16-bit coarse and fine control for each effect.

### *Dimmer options*

Four different dimming curves are available (see 'Dimmer settings' on page 21).

The dimming curve can be set by DMX using the Special Function control channel (ch15).

- Linear: hold Special Function between 60-64 for 1 second.
- Square (default): hold Special Function between 65-69 for 1 second.
- Inverse Square: hold Special Function between 70-74 for 1 second.
- S-curve: hold Special Function between 75-79 for 1 second.

The dimming curve can also be selected from the control menu.

## Strobe effects

The fixture electronically provides instant open and blackout, variable speed flash from 3 to 20 flashes per second, and random strobe effects. Separate control channels are provided for the beam effect and ring effect.

## Colors

The fixture has two separate effect elements, the LED beam effect and the LED ring effect. Both can produce any color using a combination of red, green and blue LEDs; the LED beam also has white emitters.

In Extended (93-channel) mode the LED ring is divided into 24 cells, each of which have independent red, green and blue control. These can be used for pixel mapping or for further effects. In Basic (24-channel) mode the LED ring is controlled as a single element.

In either mode, color FX (pre-programmed animation macros) can be run on the LED ring using the two FX channels. The first channel selects the effect and the second channel selects the speed of the effect.

A Color channel is provided for both the beam and the ring which allows you to select a range of preset colors using Lee filter numbers. You can also select a Color Wheel Rotation effect at varying speeds, and a random color selection mode. When the Color channel is above zero, the red, green and blue control channels have no effect.

# Maintenance



**Warning! Read ‘Safety information’ on page 5 before servicing the fixture.**

There are no user serviceable parts inside the fixture. Do not open the housing. Refer any service operation not described in this user manual to a qualified service technician.

Disconnect the fixture from mains power before cleaning or servicing.

Service fixtures in an area where there is no risk of injury from failing parts, tools or other materials.

The user may carry out the service operations described in this manual. All other service operations must be carried out by an authorized Martin® service technician. Do not try to repair the fixture yourself, as you may create a safety risk or cause damage that is not covered by the product warranty.

Installation, on-site service and maintenance can be provided worldwide by the Martin Professional™ Global Service organization and its approved agents, giving owners access to Martin’s expertise and product knowledge in a partnership that will ensure the highest level of performance throughout the product’s lifetime. Please contact Martin® for details.

## Cleaning

Excessive dust, smoke fluid, and particle buildup degrades performance, causes overheating and will damage the fixture. Damage caused by inadequate cleaning or maintenance is not covered by the product warranty.

The cleaning of external optical lenses must be carried out periodically to optimize light output. Cleaning schedules for lighting fixtures vary greatly depending on the operating environment. It is therefore impossible to specify precise cleaning intervals for the fixture. Environmental factors that may result in a need for frequent cleaning include:

- Use of smoke or fog machines.
- High airflow rates (near air conditioning vents, for example).
- Presence of cigarette smoke.
- Airborne dust (from stage effects, building structures and fittings or the natural environment at outdoor events, for example).

If one or more of these factors is present, inspect fixtures within their first 100 hours of operation to see whether cleaning is necessary. Check again at frequent intervals. This procedure will allow you to assess cleaning requirements in your particular situation. If in doubt, consult your Martin dealer about a suitable maintenance schedule.

Use gentle pressure only when cleaning, and work in a clean, well-lit area. Do not use any product that contains solvents or abrasives, as these can cause surface damage.

To clean the fixture:

1. Disconnect the fixture from power and allow it to cool for at least 10 minutes.
2. Vacuum or gently blow away dust and loose particles from the outside of the fixture and the air vents at the back and sides of the head and in the base with low-pressure compressed air.
3. Clean surfaces by wiping gently with a soft, clean lint-free cloth moistened with a weak detergent solution. Do not rub glass surfaces hard: lift particles off with a soft repeated press. Dry with a soft, clean, lint-free cloth or low-pressure compressed air. Remove stuck particles with an unscented tissue or cotton swab moistened with glass cleaner or distilled water.
4. Check that the fixture is dry before reapplying power.

## **Replacing the primary fuse**

If the fixture is completely dead, the fixture's primary fuse may have blown and it may be necessary to install a new fuse. This fuse is located in the fuse holder to the right of the mains input/output connectors. Replace with a fuse of the same size and specified rating only.

If you need to replace the fuse:

1. Disconnect the fixture from power and allow it to cool.
2. Remove the fuse holder and replace the spent fuse.
3. Close the fuse holder before reapplying power.

## **Service and repairs**

Never try to repair the fixture by yourself as this may result in damage or malfunction and it may potentially void your product warranty. The equipment must only be serviced or repaired by an authorized Martin service technician.

# DMX protocol

## Basic (24-channel) mode

Channel	Value	Function	Fade type	Default value
<b>Beam Section</b>				
<b>1</b>	000-031	<b>Strobe</b> Close	Snap	50
	032-063	Open		
	064-095	Strobe (Slow→Fast)		
	096-127	Fast Close, Slow Open		
	128-159	Fast Open, Slow Close		
	160-191	Pulse Effects		
	192-223	Random Strobe (Slow→Fast)		
	224-255	Shutter Open		
<b>2</b>	000-255	<b>Dimmer Coarse</b> 0-100%	Fade	0
<b>3</b>	000-255	<b>Dimmer Fine</b>	Fade	0
<b>4</b>	000-255	<b>Red</b> 0-100%	Fade	255
<b>5</b>	000-255	<b>Green</b> 0-100%	Fade	255
<b>6</b>	000-255	<b>Blue</b> 0-100%	Fade	255
<b>7</b>	000-255	<b>White</b> 0-100%	Fade	0
<b>8</b>	000-009	<b>Color</b> Open	Snap	0
	010-014	LEE790 - Moroccan Pink		
	015-019	LEE157 - Pink		
	020-024	LEE332 - Special Rose Pink		
	025-029	LEE328 - Follies Pink		
	030-034	LEE345 - Fuchsia Pink		
	035-039	LEE194 - Surprise Pink		
	040-044	LEE181 - Congo Blue		
	045-049	LEE071 - Tokyo Blue		
	050-054	LEE120 - Deep Blue		
	055-059	LEE079 - Just Blue		
	060-064	LEE132 - Medium Blue		
	065-069	LEE200 - Double CT Blue		
	070-074	LEE0161 - Slate Blue		
	075-079	LEE0201 - Full CT Blue		
	080-084	LEE202 - Half CT Blue		
	085-089	LEE117 - Steel Blue		
	090-094	LEE353 - Lighter Blue		
	095-099	LEE118 - Light Blue		
	100-104	LEE116 - Medium Blue Green		
105-109	LEE124 - Dark Green			
110-114	LEE139 - Primary Green			

Channel	Value	Function	Fade type	Default value
<b>8</b> <b>(contd.)</b>	115-119	LEE089 - Moss Green		
	120-124	LEE122 - Fern Green		
	125-129	LEE738 - JAS Green		
	130-134	LEE088 - Lime Green		
	135-139	LEE100 - Spring Yellow		
	140-144	LEE104 - Deep Amber		
	145-149	LEE179 - Chrome Orange		
	150-154	LEE105 - Orange		
	155-159	LEE021 - Gold Amber		
	160-164	LEE778 - Millennium Gold		
	165-169	LEE135 - Deep Golden Amber		
	170-174	LEE164 - Flame Red		
	175-179	Open		
	180-201	<b>Color wheel rotation effect</b> Clockwise Fast → Slow		
	202-207	Stop		
	208-229	Clockwise Slow → Fast		
230-234	Open			
235-239	<b>Random color effect</b> Fast			
240-244	Medium			
245-249	Slow			
250-255	Open			
<b>9</b>	000-255	<b>Pan 0-540°</b>	Fade	32768
<b>10</b>	000-255	<b>Pan fine</b>		
<b>11</b>	000-255	<b>Tilt 0-270°</b>	Fade	32768
<b>12</b>	000-255	<b>Tilt Fine</b>		
<b>13</b>	000-002	<b>Pan Rotate</b> No function (fixture in positioning mode)	Fade	0
	003-126	Rotation CW Fast → CW Slow		
	127-129	No rotation (fixture stops at its current position)		
	130-253	Rotation CCW Slow → CCW Fast		
254-255	No rotation (fixture stops at its current position)			
<b>14</b>	000-002	<b>Tilt Rotate</b> No function (fixture in positioning mode)	Fade	0
	003-126	Rotation CW Fast → CW Slow		
	127-129	No rotation (fixture stops at its current position)		
	130-253	Rotation CCW Slow → CCW Fast		
254-255	No rotation (fixture stops at its current position)			



Channel	Value	Function	Fade type	Default value
<b>15</b>	000-009	<b>Special Functions</b> No function (disables calibration)	Snap	0
	010-014	Reset fixture		
	015-054	No function		
	055-059	Enable Calibration (5 sec.)		
	060-064	Linear dimmer curve (1 sec.)		
	065-069	Square law dimmer curve (default) (1 sec.)		
	070-074	Inverse square law dimmer curve (1 sec.)		
	075-079	S-Curve dimmer curve (1 sec.)		
	080-084	Pan/Tilt Speed = Normal (1 sec.)		
	085-089	Pan/Tilt Speed = Smooth (1 sec.)		
	090-094	Pixel FX = Snap (default) (1 sec.)		
	095-099	Pixel FX = Fade (1 sec.)		
	100-144	No function		
	145-149	Auto-blackout on (1 sec.)		
	150-154	Auto-blackout off (default) (1 sec.)		
	155-159	Turn On Display On Fixture (1 sec.)		
	160-164	Turn Off Display On Fixture (1 sec.)		
	165-169	Store Pan/Tilt Calibration (5 sec.)		
	170-244	No function		
	245-249	Reset all calibration values to factory default (5 sec.)		
250-255	No function			
<b>Ring Section</b>				
<b>16</b>	000-031	<b>Strobe</b> Close	Snap	50
	032-063	Open		
	064-095	Strobe (Slow→Fast)		
	096-127	Fast Close, Slow Open		
	128-159	Fast Open, Slow Close		
	160-191	Pulse Effects		
	192-223	Random Strobe (Slow→Fast)		
	224-255	Shutter Open		
<b>17</b>	000-255	<b>Dimmer</b> 0-100%	Fade	0
<b>18</b>	000-255	<b>Dimmer Fine</b> 0-100%		
<b>19</b>	000-255	<b>Red</b> 0-100%	Fade	255
<b>20</b>	000-255	<b>Green</b> 0-100%	Fade	255
<b>21</b>	000-255	<b>Blue</b> 0-100%	Fade	255

22	000-009 010-014 015-019 020-024 025-029 030-034 035-039 040-044 045-049 050-054 055-059 060-064 065-069 070-074 075-079 080-084 085-089 090-094 095-099 100-104 105-109 110-114 115-119 120-124 125-129 130-134 135-139 140-144 145-149 150-154 155-159 160-164 165-169 170-174 175-179  180-201 202-207 208-229 230-234  235-239 240-244 245-249 250-255	<b>Color Presets</b> Open LEE790 - Moroccan Pink LEE157 - Pink LEE332 - Special Rose Pink LEE328 - Follies Pink LEE345 - Fuchsia Pink LEE194 - Surprise Pink LEE181 - Congo Blue LEE071 - Tokyo Blue LEE120 - Deep Blue LEE079 - Just Blue LEE132 - Medium Blue LEE200 - Double CT Blue LEE0161 - Slate Blue LEE0201 - Full CT Blue LEE202 - Half CT Blue LEE117 - Steel Blue LEE353 - Lighter Blue LEE118 - Light Blue LEE116 - Medium Blue Green LEE124 - Dark Green LEE139 - Primary Green LEE089 - Moss Green LEE122 - Fern Green LEE738 - JAS Green LEE088 - Lime Green LEE100 - Spring Yellow LEE104 - Deep Amber LEE179 - Chrome Orange LEE105 - Orange LEE021 - Gold Amber LEE778 - Millennium Gold LEE135 - Deep Golden Amber LEE164 - Flame Red Open <b>Color wheel rotation effect</b> Clockwise Fast →Slow Stop Clockwise Slow→Fast Open <b>Random color effect</b> Fast Medium Slow Open	Snap	0
----	---	--	------	---

<p><b>23</b></p>	<p>000-009 010-020 021-031 032-042 043-053 054-064 065-075 076-086 087-097 098-108 109-119 120-130  131-141 142-152  153-163 164-174 175-185 186-196 197-207 208-218 219-229 230-240 241-251 252-255</p>	<p><b>Color FX</b> Open FX 1 (Pixel chase, clockwise) FX 2 (Pixel chase, counterclockwise) FX 3 (Pixel bounce effect) FX 4 (Pixel fill, horizontal) FX 5 (Pixel fill, vertical) FX 6 (Dual bounce effect) FX 7 (Pixel wave, horizontal) FX 8 (Pixel wave, vertical) FX 9 (Sparkle) FX 10 (Quarter rotation, clockwise) FX 11 (Quarter rotation, counterclockwise) FX 12 (Eights rotation, clockwise) FX 13 (Eights rotation, counterclockwise) FX 14 (Split rotation, clockwise) FX 15 (Split rotation, counterclockwise) FX 16 (Quarter flip) FX 17 (Half flip, vertical) FX 18 (Half flip, horizontal) FX 19 (RGB color flash) FX 20 (Rainbow flash) FX 21 (Hot and cold flash) FX 22 (White and blue flash) Open</p>	<p>Snap</p>	<p>0</p>
<p><b>24</b></p>	<p>000-009 010-255</p>	<p><b>Color FX speed</b> Open Color FX speed Slow→Fast</p>	<p>Fade</p>	<p>60</p>

## Extended (93-channel) mode

Channel	Value	Function	Fade type	Default value
<b>Beam Section</b>				
<b>1</b>	000-031	<b>Strobe</b> Close	Snap	50
	032-063	Open		
	064-095	Strobe (Slow→Fast)		
	096-127	Fast Close, Slow Open		
	128-159	Fast Open, Slow Close		
	160-191	Pulse Effects		
	192-223	Random Strobe (Slow→Fast)		
	224-255	Shutter Open		
<b>2</b>	000-255	<b>Dimmer Coarse</b> 0-100%	Fade	0
<b>3</b>	000-255	<b>Dimmer Fine</b>	Fade	0
<b>4</b>	000-255	<b>Red</b> 0-100%	Fade	255
<b>5</b>	000-255	<b>Green</b> 0-100%	Fade	255
<b>6</b>	000-255	<b>Blue</b> 0-100%	Fade	255
<b>7</b>	000-255	<b>White</b> 0-100%	Fade	0
<b>8</b>	000-009	<b>Color</b> Open	Snap	0
	010-014	LEE790 - Moroccan Pink		
	015-019	LEE157 - Pink		
	020-024	LEE332 - Special Rose Pink		
	025-029	LEE328 - Follies Pink		
	030-034	LEE345 - Fuchsia Pink		
	035-039	LEE194 - Surprise Pink		
	040-044	LEE181 - Congo Blue		
	045-049	LEE071 - Tokyo Blue		
	050-054	LEE120 - Deep Blue		
	055-059	LEE079 - Just Blue		
	060-064	LEE132 - Medium Blue		
	065-069	LEE200 - Double CT Blue		
	070-074	LEE0161 - Slate Blue		
	075-079	LEE0201 - Full CT Blue		
	080-084	LEE202 - Half CT Blue		
	085-089	LEE117 - Steel Blue		
	090-094	LEE353 - Lighter Blue		
	095-099	LEE118 - Light Blue		
	100-104	LEE116 - Medium Blue Green		
105-109	LEE124 - Dark Green			
110-114	LEE139 - Primary Green			
115-119	LEE089 - Moss Green			
120-124	LEE122 - Fern Green			

Channel	Value	Function	Fade type	Default value
	125-129 130-134 135-139 140-144 145-149 150-154 155-159 160-164 165-169 170-174 175-179	LEE738 - JAS Green LEE088 - Lime Green LEE100 - Spring Yellow LEE104 - Deep Amber LEE179 - Chrome Orange LEE105 - Orange LEE021 - Gold Amber LEE778 - Millennium Gold LEE135 - Deep Golden Amber LEE164 - Flame Red Open <b>Color wheel rotation effect</b> Clockwise Fast ->Slow Stop Clockwise Slow->Fast Open <b>Random color effect</b> Fast Medium Slow Open		
<b>9</b>	000-255	<b>Pan 0-540°</b>	Fade	32768
<b>10</b>	000-255	<b>Pan fine</b>		
<b>11</b>	000-255	<b>Tilt 0-270°</b>		
<b>12</b>	000-255	<b>Tilt Fine</b>		
<b>13</b>	000-002 003-126 127-129  130-253 254-255	<b>Pan Rotate</b> No Function Rotation CW Fast→CW Slow No rotation (fixture stops at its current position) Rotation CCW Slow→CCW Fast No rotation (fixture stops at its current position)	Fade	0
<b>14</b>	000-002 003-126 127-129  130-253 254-255	<b>Tilt Rotate</b> No Function Rotation CW Fast→CW Slow No rotation (fixture stops at its current position) Rotation CCW Slow→CCW Fast No rotation (fixture stops at its current position)	Fade	0

Channel	Value	Function	Fade type	Default value
<b>15</b>	000-009	<b>Special Functions</b> No Function (disables calibration)	Snap	0
	010-014	Reset fixture		
	015-054	No Function		
	055-059	Enable Calibration (5 sec.)		
	060-064	Linear dimmer curve (1 sec.)		
	065-069	Square law dimmer curve (default) (1 sec.)		
	070-074	Inverse square law dimmer curve (1 sec.)		
	075-079	S-Curve dimmer curve (1 sec.)		
	080-084	Pan/Tilt Speed = Normal (1 sec.)		
	085-089	Pan/Tilt Speed = Smooth (1 sec.)		
	090-094	Pixel FX = Snap (default) (1 sec.)		
	095-099	Pixel FX = Fade (1 sec.)		
	100-144	No Function		
	145-149	Auto-blackout on (1 sec.)		
	150-154	Auto-blackout off (default) (1 sec.)		
	155-159	Turn On Display On Fixture (1 sec.)		
	160-164	Turn Off Display On Fixture (1 sec.)		
	165-169	Store Pan/Tilt Calibration (5 sec.)		
	170-244	No Function		
	245-249	Reset all calibration values to factory defaults (5 sec.)		
250-255	No Function			
<b>Ring Section</b>				
<b>16</b>	000-031	<b>Strobe</b> Close	Snap	50
	032-063	Open		
	064-095	Strobe (Slow→Fast)		
	096-127	Fast Close, Slow Open		
	128-159	Fast Open, Slow Close		
	160-191	Pulse Effects		
	192-223	Random Strobe (Slow→Fast)		
	224-255	Shutter Open		
<b>17</b>	000-255	<b>Dimmer 0-100%</b>	Fade	0
<b>18</b>	000-255	<b>Dimmer Fine</b>		

<p><b>19</b></p>	<p>000-009 010-014 015-019 020-024 025-029 030-034 035-039 040-044 045-049 050-054 055-059 060-064 065-069 070-074 075-079 080-084 085-089 090-094 095-099 100-104 105-109 110-114 115-119 120-124 125-129 130-134 135-139 140-144 145-149 150-154 155-159 160-164 165-169 170-174 175-179  180-201 202-207 208-229 230-234  235-239 240-244 245-249 250-255</p>	<p><b>Color Presets</b> Open LEE790 - Moroccan Pink LEE157 - Pink LEE332 - Special Rose Pink LEE328 - Follies Pink LEE345 - Fuchsia Pink LEE194 - Surprise Pink LEE181 - Congo Blue LEE071 - Tokyo Blue LEE120 - Deep Blue LEE079 - Just Blue LEE132 - Medium Blue LEE200 - Double CT Blue LEE0161 - Slate Blue LEE0201 - Full CT Blue LEE202 - Half CT Blue LEE117 - Steel Blue LEE353 - Lighter Blue LEE118 - Light Blue LEE116 - Medium Blue Green LEE124 - Dark Green LEE139 - Primary Green LEE089 - Moss Green LEE122 - Fern Green LEE738 - JAS Green LEE088 - Lime Green LEE100 - Spring Yellow LEE104 - Deep Amber LEE179 - Chrome Orange LEE105 - Orange LEE021 - Gold Amber LEE778 - Millennium Gold LEE135 - Deep Golden Amber LEE164 - Flame Red Open <b>Color wheel rotation effect</b> Clockwise Fast→Slow Stop Clockwise Slow→Fast Open <b>Random color effect</b> Fast Medium Slow Open</p>	<p>Snap</p>	<p>0</p>
------------------	--	---	-------------	----------

<b>20</b>	000-009 010-020 021-031 032-042 043-053 054-064 065-075 076-086 087-097 098-108 109-119 120-130  131-141 142-152  153-163 164-174  175-185 186-196 197-207 208-218 219-229 230-240 241-251 252-255	<b>Color FX</b> Open FX 1 (Pixel chase, clockwise) FX 2 (Pixel chase, counterclockwise) FX 3 (Pixel bounce effect) FX 4 (Pixel fill, horizontal) FX 5 (Pixel fill, vertical) FX 6 (Dual bounce effect) FX 7 (Pixel wave, horizontal) FX 8 (Pixel wave, vertical) FX 9 (Sparkle) FX 10 (Quarter rotation, clockwise) FX 11 (Quarter rotation, counterclockwise) FX 12 (Eights rotation, clockwise) FX 13 (Eights rotation, counterclockwise) FX 14 (Split rotation, clockwise) FX 15 (Split rotation, counterclockwise) FX 16 (Quarter flip) FX 17 (Half flip, vertical) FX 18 (Half flip, horizontal) FX 19 (RGB color flash) FX 20 (Rainbow flash) FX 21 (Hot and cold flash) FX 22 (White and blue flash) Open	Snap	0
<b>21</b>	000-009 010-255	<b>Color FX speed</b> Open Color FX speed Slow→Fast	Fade	60
<b>22</b>	000-255	<b>Cell 1 Red</b> 0-100%	Fade	255
<b>23</b>	000-255	<b>Cell 1 Green</b> 0-100%	Fade	255
<b>24</b>	000-255	<b>Cell 1 Blue</b> 0-100%	Fade	255
<i>... Repeat for RGB Cells 2-23 ...</i>				
<b>91</b>	000-255	<b>Cell 24 Red</b> 0-100%	Fade	255
<b>92</b>	000-255	<b>Cell 24 Green</b> 0-100%	Fade	255
<b>93</b>	000-255	<b>Cell 24 Blue</b> 0-100%	Fade	255



## Control menus

To access the control menus, press the MENU button. Use the UP and DOWN buttons to navigate the menus. Select a menu option with the ENTER button. For more information, see 'Using the control menus' on page 18.

Default fixture settings are shown in **bold**.

Menu	Sub-menu	Explanation
DMX Address	1–512	Fixture DMX address setting
Channel Mode	<b>Basic 24ch</b>	No pixel map of Ring
	Extended 93ch	Pixel map Ring
Show Mode	<b>Show 1</b> ...Show 4	Select stand-alone program
Master Slave	Master	Fixture acts as master
	<b>Slave 1</b>	Slave copies master
	Slave 2	Slave synced by master
Sound Mode	On	Toggle music trigger for stand-alone operation
	<b>Off</b>	
Sound Sense	0...100 (default <b>90</b> )	Microphone sensitivity for music trigger
DMX State	Show Mode	Fixture behavior if DMX control signal is missing or lost
	Blackout	
	<b>Hold</b>	
Dimmer Curve	Mode 1	Optically linear
	<b>Mode 2</b>	Square law
	Mode 3	Inverse square law
	Mode 4	S-curve
Dimmer Speed	Fade	Smoother dimming
	<b>Snap</b>	Faster dimming
Back light	On	Toggle display panel backlight
	<b>Off</b>	
Pan Inverse	Yes	Invert pan control
	<b>No</b>	Normal pan control
Tilt Inverse	Yes	Invert tilt control
	<b>No</b>	Normal tilt control

Menu	Sub-menu	Explanation
Function Delay	no delay 1s delay 2s delay <b>3s delay</b>	Adds a delay before function changes are activated on the Special Function channel
White Balance	Red	set brightness 125-255
	Green	set brightness 125-255
	Blue	set brightness 125-255
Manual Test	Pan	0-255
	RPan ( <i>Pan rotate</i> )	0-255
	Tilt	0-255
	RTilt ( <i>Tilt rotate</i> )	0-255
	Red	0-255
	Green	0-255
	Blue	0-255
	White	0-255
	ArRed ( <i>Ring Red</i> )	0-255
	ArGreen ( <i>Ring Green</i> )	0-255
	ArBlue ( <i>Ring Blue</i> )	0-255
	Dimmer	0-255
Strobe	0-255	
Auto Test		
LED Temp.		Temperature readout
Fan Mode	<b>Auto</b>	Optimize cooling for light output intensity
	Low	Optimize cooling for quietness (output intensity is reduced if necessary to limit temperature)
Firmware Version		Currently installed firmware version
Fixture Time		Fixture operating hours counter
PRO Defaults	Yes	Restore factory default settings
	<b>No</b>	Exit

Menu	Sub-menu	Explanation
Reset	Yes	Force a fixture motor reset
	No	

To access the Offset menu, press MENU to enter the menu structure and then press and hold ENTER for three seconds.

Menu	Sub-menu	Setting	Explanation
Offset Menu	Pan	-127→127	Pan offset
	Tilt	-127→127	Tilt offset

# Troubleshooting

This section describes a few common problems that may occur during operation and provides some suggestions for easy troubleshooting:

Symptom	Potential Causes	Remedies
No light from fixture, or fans not working.	Power supply issue such as blown fuse, faulty connector or damaged cable.	<p>Ensure that the mains supply is connected and supplying power to the fixture.</p> <p>Check all power connections and cables.</p> <p>Check and if necessary replace the fixture fuse.</p>
One of the control channels is unresponsive or only responds intermittently.	<p>DMX setup or DMX link fault.</p> <p>Damaged step motor or cable connection between head and body.</p>	<p>See next section.</p> <p>Contact your Martin authorized distributor or service center for assistance.</p>
Fixture does not respond to DMX control.	Fault in the DMX network due to connector or cable damage, incorrect DMX addressing, or potential interference from proximity to a high voltage installation.	<p>Ensure that fixture's DMX address matches address set on DMX control device.</p> <p>Check that fixture DMX LED is on, and if not, check all DMX cables and connections.</p> <p>Ensure that DMX link is terminated.</p> <p>Check that all components on DMX link use standard DMX polarity.</p> <p>Attempt to control the fixture with another DMX control device.</p> <p>Move or shield link if it is close to an unshielded high-voltage installation.</p>

# Specifications

## Physical

Dimensions (LxWxH).....275 x 188 x 325 mm (10.8 x 7.4 x 12.8 in.)  
 Weight .....7.5 kg (16.5 lbs.)

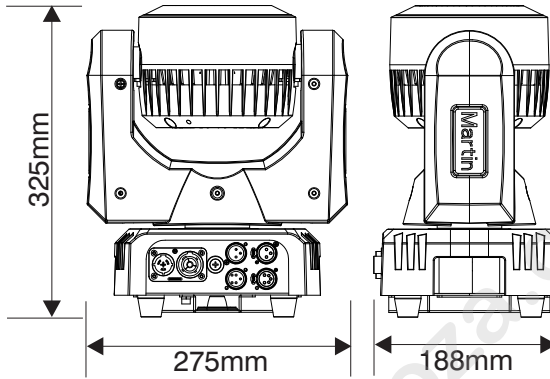

## Dynamic Effects

Beam color mixing ..... RGBW  
 Ring color mixing ..... RGB, grouped or individual control of 24 cells  
 Virtual color wheel ..... 33 color presets, virtual color wheel rotation effects, random color (independent in beam and ring)  
 Pre-programmed effects ..... FX (effect macros) in ring with variable speed and direction of sequences, synchronization and chases across multiple fixtures  
 Dimming ..... 0-100%, coarse and fine control (independent in beam and ring)  
 Electronic shutter effect ..... Strobe effect, pulse effects, instant open and blackout (independent in beam and ring)  
 Pan ..... Continuous rotation or 540° positioning  
 Tilt ..... Continuous rotation or 270° positioning  
 Strobe ..... Variable from 3 - 20 Hz, pulse effects and random strobe  
 Electronic dimming ..... 0 - 100%, four dimming curve options

## Optics

Beam effect light source ..... 60 W RGBW Osram LE RTDUW S2WP  
 Ring effect light source ..... 24 x 0.25 W RGB LED  
 Cutoff beam angle ..... 4.4°  
 Minimum LED lifetime ..... 20 000 hours (to >70% luminous output)\*

*\*Figure obtained under manufacturer's test conditions*

## Control and Programming

Control options .....	DMX, RDM, stand-alone, master/slave
DMX channels .....	24 or 93
Stand-alone trigger options .....	Music trig, auto trig
Stand-alone memory .....	4 shows
Setting and addressing .....	Control panel with backlit LCD display
Pan and tilt speed.....	Adjustable via onboard control panel and DMX
DMX compliance .....	USITT DMX512/1990
RDM compliance.....	ANSI/ESTA E.120

## Construction

Color .....	Black
Housing .....	High impact flame retardant thermoplastic
IP rating .....	IP 20

## Installation

Mounting points .....	One quarter-turn bracket for rigging clamp
Location .....	Dry location only, must be fastened to surface or structure
Orientation .....	Any
Minimum distance to illuminated surfaces .....	200 mm (8 in.)
Minimum distance to combustible materials .....	100 mm (4 in.)
Minimum clearance around fans and vents .....	100 mm (4 in.)

## Connections

AC power input/output.....	Neutrik powerCON TRUE1
DMX/RDM data in/out .....	3-pin & 5-pin locking XLR

## Electrical

AC power.....	100-240 V nominal, 50/60 Hz
Power supply unit.....	Auto-ranging electronic switch mode
Fuse .....	T 2.0 A

## Typical power and current

120 V, 60 Hz.....	0.85 A, 100W, PF 0.99
230 V, 50 Hz.....	0.49 A, 108W, PF 0.99

*Measurements made at nominal voltage with all LEDs at full intensity. Allow for a deviation of +/- 10%.*

## Approvals



EU safety .....	EN 60598-2-17 (EN 60598-1), EN 62471, EN 62493
EU EMC .....	EN 55015; EN 55032; EN 55103-1,-2; EN 61000-3-2,-3; EN 61000-4-2, -4, -5; EN 61547
US safety.....	UL 1573

US EMC.....	FCC Part 15 Class A
Canadian safety .....	CSA C22.2 No. 166
Canadian EMC .....	ICES-003 Class A
Australia/NZ.....	RCM

**Thermal**

Cooling .....	Forced air (temperature regulated, low noise)
Maximum ambient temperature (T <sub>a</sub> max.).....	40° C (104° F)
Minimum ambient temperature (T <sub>a</sub> min).....	0°C (32° F)

**Included Items**

- Power cable, 1.5 m (4.9 ft.) 18AWG/0.75mm<sup>2</sup> without mains plug
- Omega bracket for rigging clamp attachment

**Accessories**

*Input cables, 16 A, for connection to power*

- Power Input Cable, H07RN-F, 2.5 mm<sup>2</sup>,  
Neutrik TRUE1 NAC3FX-W to bare ends, 1.5 m (4.9 ft.)..... P/N 91611797
- Power Input Cable, H07RN-F, 2.5 mm<sup>2</sup>,  
Neutrik TRUE1 NAC3FX-W to bare ends, 5 m (16.4 ft.)..... P/N 91611786
- Power Input Cable, SJOOW, AWG 12,  
Neutrik TRUE1 NAC3FX-W to bare ends, 1.5 m (4.9 ft.)..... P/N 91610173
- Power Input Cable, SJOOW, AWG 12,  
Neutrik TRUE1 NAC3FX-W to bare ends, 5 m (16.4 ft.)..... P/N 91610174

*Relay cables, 16 A, for relaying power in chains*

- Power Relay Cable, H07RN-F, 2.5 mm<sup>2</sup>,  
Neutrik TRUE1 to TRUE1, 0.45 m (1.5 ft.)..... P/N 91611784
- Power Relay Cable, H07RN-F, 2.5 mm<sup>2</sup>,  
Neutrik TRUE1 to TRUE1 1.2 m (3.9 ft.)..... P/N 91611785
- Power Relay Cable, H07RN-F, 2.5 mm<sup>2</sup>,  
Neutrik TRUE1 to TRUE1 2.5 m (8.2 ft.)..... P/N 91611796
- Power Relay Cable, SJOOW, AWG 12,  
Neutrik TRUE1 to TRUE1, 0.45 m (1.5 ft.)..... P/N 91610170
- Power Relay Cable, SJOOW, AWG 12,  
Neutrik TRUE1 to TRUE1, 1.2 m (3.9 ft.)..... P/N 91610171
- Power Relay Cable, SJOOW, AWG 12,  
Neutrik TRUE1 to TRUE1, 2.5 m (8.2 ft.)..... P/N 91610172

*Power connectors, cable mount*

- Neutrik PowerCON TRUE1 NAC3MX-W (male)..... P/N 91611788
- Neutrik PowerCON TRUE1 NAC3FX-W (female)..... P/N 91611789

*Installation hardware*

Half-coupler clamp .....	P/N 91602005
G-clamp* .....	P/N 91602003
Quick-trigger clamp* .....	P/N 91602007
Safety cable, safe working load 60 kg, black .....	P/N 91604006
Safety cable, safe working load 60 kg, silver .....	P/N 91604007

*\*Use with fixture hanging vertically downwards only*

**Related Items**

RUSH® Software Uploader 1 .....	P/N 91611399
Martin® Companion uploader software with Martin® M-DMX Interface .....	See <a href="http://www.martin.com">www.martin.com</a>

**Ordering Information**

RUSH® MH 10 Beam FX in cardboard box .....	P/N 90280120
--	--------------

*Specifications subject to change without notice. For latest product specifications, see [www.martin.com](http://www.martin.com)*

*www.carlosmendoza.com.mx*





### Disposing of this product

RUSH by Martin® products are supplied in compliance with Directive 2012/19/EC of the European Parliament and of the Council of the European Union on WEEE (Waste Electrical and Electronic Equipment), where applicable. Help preserve the environment! Ensure that this product is recycled at the end of its life. Your supplier can give details of local arrangements for the disposal of RUSH by Martin products

### Photobiological Safety Warning

The label shown below is displayed on this product. If it becomes difficult or impossible to read, it must be replaced using the illustration below to reproduce new labels sized 18 x 45 mm (each label), in black on a yellow background.

#### **RISK GROUP 2**

**CAUTION.** Possibly hazardous optical radiation emitted from this product.  
Do not stare at operating lamp. May be harmful to the eyes.

#### **GROUPE DE RISQUE 2**

**PRUDENCE.** Produit à émission de radiations visibles potentiellement dangereuses.  
Ne pas fixer le faisceau en fonctionnement.  
Risque de lésions oculaires.



