

# MAC Aura™

## User manual



**Martin**®

# Dimensions

All dimensions are in millimeters

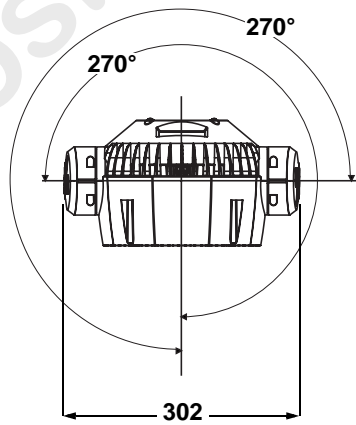
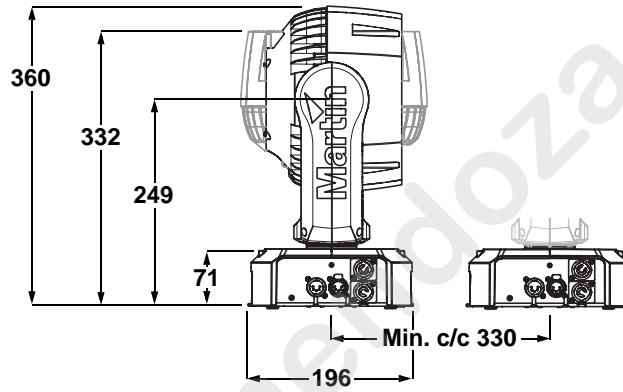
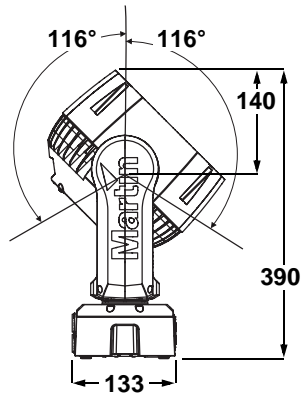

www.carlosmedoza.com.mx

# Safety Information



**WARNING!**  
**Read the safety precautions in this section before installing, powering, operating or servicing this product.**

The following symbols are used to identify important safety information on the product and in this manual:



**DANGER!**  
Safety hazard.  
Risk of severe injury or death.



**DANGER!**  
Hazardous voltage. Risk of lethal or severe electric shock.



**WARNING!**  
Fire hazard.



**WARNING!**  
LED light emission. Risk of eye injury.



**WARNING!**  
Burn hazard. Hot surface. Do not touch.



**WARNING!**  
Wear protective eyewear.



**WARNING!**  
Refer to user manual.



**Warning! Risk Group 3 (high risk) LED product according to EN 62471. Do not view the light output with optical instruments or any device that may concentrate the beam.**



This product is for professional use only. It is not for household use.

This product presents risks of severe injury or death due to fire and burn hazards, electric shock and falls.



**Read this manual** before installing, powering or servicing the fixture, follow the safety precautions listed below and observe all warnings in this manual and printed on the fixture. If you have questions about how to operate the fixture safely, please contact your Martin supplier or call the Martin 24-hour service hotline on +45 8740 0000, or in the USA on 1-888-tech-180.



## PROTECTION FROM ELECTRIC SHOCK

- Disconnect the fixture from AC power before removing or installing any cover or part and when not in use.
- Always ground (earth) the fixture electrically.
- Use only a source of AC power that complies with local building and electrical codes and has both overload and ground-fault (earth-fault) protection.
- Before using the fixture, check that all power distribution equipment and cables are in perfect condition and rated for the current requirements of all connected devices.
- Power input and throughput cables must be rated 20 A minimum, have three conductors 1.5 mm<sup>2</sup> (16 AWG) minimum conductor size and an outer cable diameter of 5 - 15 mm (0.2 - 0.6 in.). Cables must be hard usage type (SJT or equivalent) and heat-resistant to 90° C (194° F) minimum. In the EU the cable must be HAR approved or equivalent.
- Use only Neutrik PowerCon NAC3FCA cable connectors to connect to power input sockets. Use only Neutrik PowerCon NAC3FCB cable connectors to connect to power throughput sockets.
- Isolate the fixture from power immediately if the power plug or any seal, cover, cable, or other component is damaged, defective, deformed, wet or showing signs of overheating. Do not reapply power until repairs have been completed.
- Do not expose the fixture to rain or moisture.

- Refer any service operation not described in this manual to a qualified technician.
- Socket outlets used to supply MAC Aura fixtures with power or external power switches must be located near the fixtures and easily accessible so that the fixtures can easily be disconnected from power.



## PROTECTION FROM BURNS AND FIRE



- Do not operate the fixture if the ambient temperature ( $T_a$ ) exceeds  $40^{\circ}\text{C}$  ( $104^{\circ}\text{F}$ ).
- The exterior of the fixture becomes hot during use. Avoid contact by persons and materials. Allow the fixture to cool for at least 10 minutes before handling.
- Keep all combustible materials (e.g. fabric, wood, paper) at least 100 mm (3.9 in.) away from the fixture.
- Keep flammable materials well away from the fixture.
- Ensure that there is free and unobstructed airflow around the fixture.
- Do not illuminate surfaces within 200 mm (7.9 ins.) of the MAC Aura.
- Do not attempt to bypass thermostatic switches or fuses.
- If you relay power from one fixture to another using power throughput sockets, do not connect more than seven MAC Aura fixtures in total to each other in an interconnected chain.
- Connect only other MAC Aura fixtures to MAC Aura power throughput sockets. Do not connect any other type of device to these sockets.
- Do not stick filters, masks or other materials onto any optical component.
- Do not modify the fixture in any way not described in this manual
- Install only genuine Martin parts.



## PROTECTION FROM INJURY



- Do not look at LEDs with magnifiers, telescopes, binoculars or similar optical instruments that may concentrate the light output.
- Fasten the fixture securely to a surface or supporting structure before applying power (see “Accessories” on page 34 for suitable mounting hardware).
- Ensure that any supporting structure and/or hardware used can hold at least 10 times the weight of all the devices they support.
- If suspending from a rigging structure, fasten the fixture to a rigging clamp with an M12 bolt screwed into the threaded hole in the center of the base of the fixture. The bolt must protrude at least 20 - 30 mm (0.8 - 1.2 ins.) into the fixture. If the fixture is suspended by any other method, an M12 bolt must be tightened into this hole so that it protrudes at least 20 - 30 mm (0.8 - 1.2 ins.) into the fixture.
- If the fixture is installed in a location where it may cause injury or damage if it falls, install as described in this manual a secondary attachment such as a safety cable that is approved by an official body such as TÜV as a safety attachment for the weight that it secures. The safety cable must comply with EN 60598-2-17 Section 17.6.6 and be capable of bearing a static suspended load that is ten times the weight of the fixture and all installed accessories.
- Allow enough clearance around the head to ensure that it cannot collide with an object or another fixture when it moves.
- Check that all external covers and rigging hardware are securely fastened.
- Block access below the work area and work from a stable platform whenever installing, servicing or moving the fixture.
- Do not operate the fixture with missing or damaged covers, shields or any optical component.



### Disposing of this product

Martin™ products are supplied in compliance with Directive 2002/96/EC of the European Parliament and of the Council of the European Union on WEEE (Waste Electrical and Electronic Equipment), as amended by Directive 2003/108/EC, where applicable.

Help preserve the environment! Ensure that this product is recycled at the end of its life. Your supplier can give details of local arrangements for the disposal of Martin products.

# Contents

Dimensions .....	2
Safety Information .....	3
Fixture overview .....	6
Introduction .....	7
Using for the first time .....	7
AC power .....	8
Power voltage .....	8
Power cables and power plug .....	8
Relaying power to other devices .....	9
Data link .....	10
Tips for reliable data transmission .....	10
Connecting the data link .....	10
Physical installation .....	11
Fastening the fixture to a flat surface .....	11
Mounting the fixture on a truss .....	11
Hanging the fixture .....	12
Quick-mount surface mounting bracket .....	12
Setup .....	13
Control panel and menu navigation .....	13
DMX address setting .....	13
Beam, Aura and FX control .....	13
Tailoring performance .....	14
Restoring factory default settings .....	15
Operation and effects .....	16
Effects .....	16
RDM .....	18
Service and maintenance .....	19
Cleaning .....	19
Control menu service utilities .....	20
Fixture readouts .....	21
Lubrication .....	21
DMX protocol .....	22
FX: pre-programmed effects .....	27
LEE colors and RGB equivalents .....	28
Onboard control menus .....	29
Display messages .....	31
Troubleshooting .....	32
Specifications .....	33

# Fixture overview

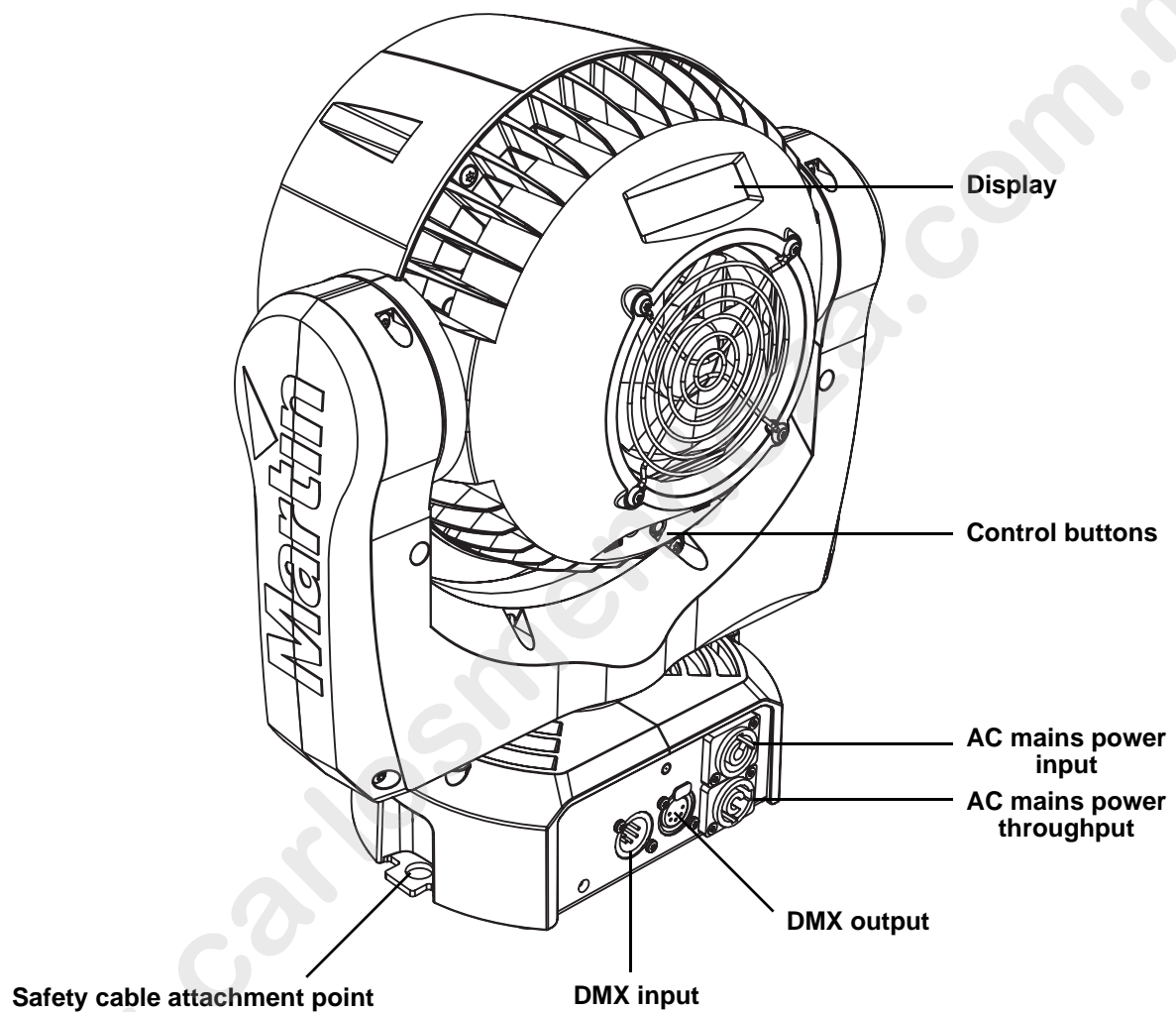

*Note: head fan grill in production models is rotated 90° compared to this illustration.*

**Figure 1: Fixture overview**

# Introduction

Thank you for selecting the MAC Aura™, an intelligent lighting fixture from Martin Professional™. This compact LED-based moving-head washlight features:

- Independent or linked Beam (primary LED array) and Aura (secondary background LED array) control
- Range of pre-programmed independent and synchronized Beam and Aura effects available via DMX that give instant access to the full potential of the fixture
- Beam RGBW color control with color temperature control
- Aura RGB control
- 'Color wheel' color snap Beam and Aura effects
- Onboard control panel and backlit LCD graphic display
- Motorized zoom
- Smooth electronic dimming
- Electronic shutter with strobe and pulse effects
- Calibrated and raw modes
- Osram Ostar high-power emitters
- DMX control and RDM fixture management
- 540° pan and 232° tilt ranges

For the latest firmware updates, documentation, and other information about this and all Martin Professional products, please visit the Martin website at <http://www.martin.com>

Comments or suggestions regarding this document may be e-mailed to [service@martin.dk](mailto:service@martin.dk) or posted to: Technical Documentation, Martin Professional A/S, Olof Palmes Allé 18, DK-8200 Aarhus N, Denmark.

## Using for the first time

***Important! The MAC Aura must be protected from environmental factors such as physical shocks and vibration during transportation and storage to a level of protection equal to that provided by Martin brand flightcases.***



***Warning! Read "Safety Information" on page 3 before installing, powering, operating or servicing the MAC Aura. Before applying power to the fixture:***

- Check the Martin Professional website at [www.martin.com](http://www.martin.com) for the most recent user documentation and technical information about the MAC Aura. Martin user manual revisions are identified by the revision letter at the bottom of page 2.
- Carefully review "Safety Information" starting on page 3.
- Check that the local AC mains power source is within the fixture's power voltage and frequency ranges.
- See "Power cables and power plug" on page 8. Install a Neutrik PowerCon NAC3FCA power input connector on a suitable power cable. If drawing power from a mains power outlet, install a suitable power plug on the power cable.

# AC power



**Warning!** Read “Safety Information” starting on page 3 before connecting the MAC Aura to AC mains power.



**Warning!** For protection from electric shock, the MAC Aura must be grounded (earthed). The power distribution circuit must be equipped with a fuse or circuit breaker and ground-fault (earth-fault) protection.

**Warning!** Socket outlets or external power switches used to supply the MAC Aura with power must be located near the fixture and easily accessible so that the fixtures can easily be disconnected from power.

**Warning!** Do not insert or remove live Neutrik PowerCon connectors to apply or cut power, as this may cause arcing at the terminals and damage the connectors.

**Important!** Do not use an external dimming system to supply power to the MAC Aura, as this may cause damage to the fixture that is not covered by the product warranty.

The MAC Aura can be hard-wired to a building electrical installation if you want to install it permanently, or a power plug that is suitable for the local power outlets can be installed on the power cable.

## Power voltage



**Warning!** Check that the voltage range specified on the fixture’s serial number label matches the local AC mains power voltage before applying power to the fixture.

MAC Aura fixtures accept AC mains power at 100-240 V nominal, 50/60 Hz. Do not apply AC mains power to the fixture at any other voltage than that specified on the fixture’s serial number label.

## Power cables and power plug

Power input and throughput cables must be rated 20 A minimum, have three conductors 1.5 mm<sup>2</sup> (16 AWG) minimum conductor size and an outer cable diameter of 5 - 15 mm (0.2 - 0.6 in.). Cables must be hard usage type (SJT or equivalent) and heat-resistant to 90° C (194° F) minimum. In the EU the cable must be HAR approved or equivalent.

If you install a power plug on the power cable, install a grounding-type (earthed) plug that is rated 20 A minimum. Follow the plug manufacturer’s instructions. Table 1 shows standard wire color-coding schemes and some possible pin identification schemes; if pins are not clearly identified, or if you have any doubts about proper installation, consult a qualified electrician.



Wire Color (EU models)	Wire Color (US models)	Conductor	Symbol	Screw (US)
brown	black	live	L	yellow or brass
blue	white	neutral	N	silver
yellow/green	green	ground (earth)	 or 	green

Table 1: Wire color-coding and power connections



## Installing a power input connector on a power cable

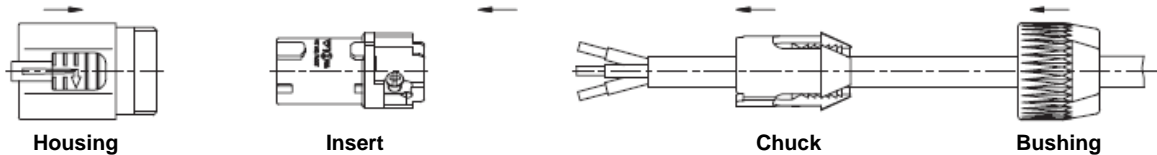

To install a Neutrik PowerCon NAC3FCA input connector on a power cable:

1. Slide the bushing over the cable.
2. Slide the white chuck over cables with a diameter ( $D_a$ ) of 5 - 10 mm (0.2 - 0.4 in.), or the black chuck over cables with a diameter of 10 - 15 mm (0.4 - 0.6 in.).
3. Prepare the end of the cable by stripping 20 mm (0.8 in.) of the cable's outer jacket.
4. Strip 8 mm (1/3 in.) from the end of each of the wires.
5. Insert each of the wire ends into the appropriate terminal (see instructions and Table 1 above) and fasten the clamping device using a small flathead screw driver.
6. Push and insert the chuck into the housing (note that there is a raised key on the chuck to ensure that it is oriented correctly).
7. Fasten the bushing using a wrench to a torque of 2.5 Nm (1.8 lb.-ft).

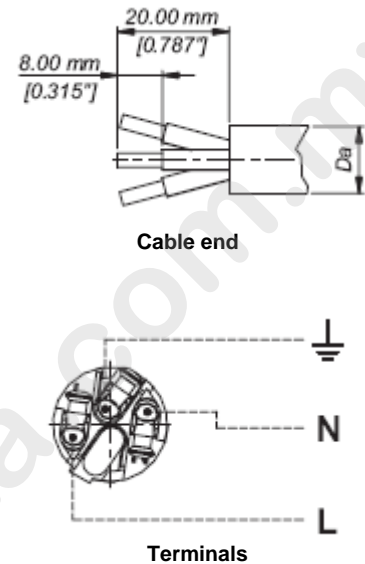

Illustrations above used by kind permission of Neutrik AG

## Relaying power to other devices



**Warning! Do not connect more than seven MAC Aura fixtures in total to AC mains power in one interconnected chain.**

Power can be relayed to another device via the light-grey PowerCon throughput socket that accepts a light-grey PowerCon NAC3FCB cable connector. Note that blue input and light-grey throughput connectors have different designs: one type cannot be connected to the other. Neutrik power connectors can be ordered separately from Martin (see Accessories on page 34).

If you link fixtures in a chain so that they all draw AC mains power via the first fixture, certain points must be respected:

- A hard usage, three-conductor, 16 AWG or 1.5 mm<sup>2</sup> cable with SJT or equivalent cable jacket must be used to connect the first fixture to AC mains power and to interconnect all the fixtures in the chain up to a maximum of seven fixtures in total.
- Light-grey Neutrik PowerCon NAC3FCB connectors must be used to draw AC mains power from the fixtures' power throughput sockets and blue Neutrik PowerCon NAC3FCA connectors must be used to supply power at the fixture's power input sockets.
- No matter what the AC mains power voltage is, *do not connect more than seven MAC Aura fixtures in total* (i.e. including the first fixture) to AC mains power in one interconnected daisy chain using power input and throughput connectors.

# Data link

A DMX 512 data link is required in order to control a MAC Aura via DMX.

The MAC Aura has 5-pin XLR connectors for DMX data input and output. The pin-out on all connectors is pin 1 = shield, pin 2 = cold (-), and pin 3 = hot (+). Pins 4 and 5 in the 5-pin XLR connectors are not used in the MAC Aura but are available for possible additional data signals as required by the DMX512-A standard. Standard pin-out is pin 4 = data 2 cold (-) and pin 5 = data 2 hot (+).

The MAC Aura is not subject to the limit of 32 devices per daisy-chained link which is common in Martin fixtures. Instead, the number of fixtures is either limited to 256 or limited by the number of DMX channels required by the fixtures in relation to the maximum 512 channels available in one DMX universe, whichever limit is lower. Note that if independent control of a fixture is required, it must have its own DMX channels. Fixtures that are required to behave identically can share the same DMX channels.

To add more fixtures or groups of fixtures when the above limit is reached, add a DMX universe and another daisy-chained link.

## Tips for reliable data transmission

- Use shielded twisted-pair cable designed for RS-485 devices: standard microphone cable cannot transmit control data reliably over long runs. 24 AWG cable is suitable for runs up to 300 meters (1000 ft). Heavier gauge cable and/or an amplifier is recommended for longer runs.
- Never use both a fixture's outputs to split a DMX link. To split the link into branches, use a splitter such as the Martin 4-Channel Opto-Isolated RS-485 Splitter/Amplifier.
- Terminate the link by installing a termination plug in the output socket of the last fixture. The termination plug, which is a male XLR plug with a 120 Ohm, 0.25 Watt resistor soldered between pins 2 and 3, "soaks up" the control signal so it does not reflect and cause interference. If a splitter is used, terminate each branch of the link.

## Connecting the data link

To connect the MAC Aura to data:

1. Connect the DMX data output from the controller to the closest MAC Aura's male 5-pin XLR DMX input connector.
2. Connect the DMX output of the fixture closest to the controller to the DMX input of the next fixture and continue connecting fixtures output to input.
3. Terminate the last fixture on the link with a 120 Ohm resistor.

# Physical installation

Warning! The MAC Aura must be either fastened to a flat surface such as a stage or wall, or clamped to a truss or similar structure in any orientation using a rigging clamp. Do not apply power to the MAC Aura if it is standing freely or the fixture can be moved.



**Warning! Attach an approved safety cable to one of the safety cable attachment points on the base (see “Fixture overview” on page 6).**

**Check that all surfaces to be illuminated are minimum 200 mm (7.9 ins.) from the fixture, that combustible materials (wood, fabric, paper, etc.) are minimum 100 mm (3.9 in.) from the fixture, that there is free airflow around the fixture and that there are no flammable materials nearby.**

**Make sure that it is impossible for the moving head to collide with another fixture or other object.**

Allow a minimum center-to-center distance of 300 mm (12 ins.) between MAC Aura fixtures.

## Fastening the fixture to a flat surface

The MAC Aura can be fastened to a stage or other flat surface. Check that the surface can support at least 10 times the weight of all fixtures and equipment to be installed on it.



**Warning! The supporting surface must be hard and flat or air vents in the base may be blocked, which will cause overheating. Fasten the fixture securely. Do not stand it on a surface or leave it where it can be moved or can fall over. Attach a securely anchored safety cable to the safety cable attachment point (see “Fixture overview” on page 6) if the fixture is to be installed in any location where it may fall and cause injury or damage.**

## Mounting the fixture on a truss

The MAC Aura can be clamped to a truss or similar rigging structure in any orientation.



**Warning! Use a rigging clamp with an M12 bolt if suspending the fixture from its base. The clamp must be screwed into the central threaded hole in the fixture base. The M12 bolt must protrude 20 - 30 mm (0.8 - 1.2 ins.) into the fixture base.**

**An M12 bolt that is suitable for many types of rigging clamp is supplied with the MAC Aura, but you must pass the bolt through the clamp and check that the distance the bolt will protrude into the fixture base is within the 20 - 30 mm limits before using it. If the bolt is not within these limits, you must find an alternative bolt that is.**

To clamp a MAC Aura to a truss:

1. Check that the rigging structure can support at least 10 times the weight of all fixtures and equipment to be installed on it.
2. Obtain a rigging clamp such as the G-clamp (P/N 91602003), Half-coupler clamp (P/N 91602005) or Quick trigger clamp (P/N 91602007)

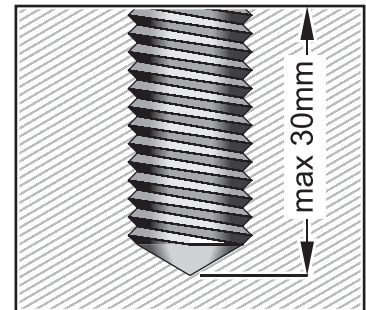
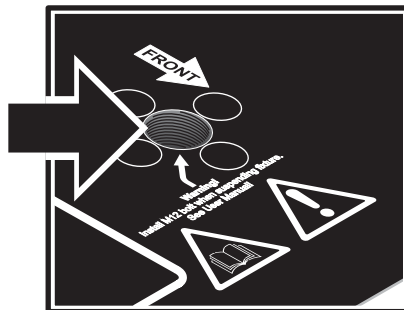

Figure 2: Rigging clamp bolt

- available as accessories from Martin. An omega bracket is not required.
3. Check that the rigging clamp is undamaged and can bear at least 10 times the weight of the fixture. Fasten the clamp to the fixture with a minimum grade 8.8 steel M12 bolt in the threaded hole in the

center of the base of the fixture. The bolt must protrude 20 - 30 mm (0.8 - 1.2 ins.) into the base of the fixture.

4. Block access under the work area. Working from a stable platform, hang the fixture on the truss with the arrow on the base towards the area to be illuminated. Tighten the rigging clamp.
5. Secure the fixture against clamp failure with a secondary attachment such as an approved safety cable that is rated for the weight of the fixture and all attached accessories and hardware using one of the attachment points at the edges of the base (see "Fixture overview" on page 6). Do not use any other part of the fixture as a safety cable attachment point.
6. Check that the head will not collide with other fixtures or objects.

## Hanging the fixture

In some regions, it may be legal to use two safety cables, one looped through one cable attachment point (see "Fixture overview" on page 6) and the other looped through the other cable attachment point, to suspend the fixture. If one cable fails, the other will provide secondary attachment.

However, this suspension method is not recommended as it will not hold the base firmly, and moving pan and tilt will cause the fixture and light beam to swing uncontrollably. Instead, we strongly recommend installation using a rigging clamp as described above.



**Warning!** If you choose to suspend using two cables anyway, you must install a minimum 8.8 grade steel M12 bolt in the rigging clamp hole in the center of the fixture's base. See Figure 2. The bolt must protrude 20 - 30 mm (0.8 - 1.2 ins.) into the base. If you do not secure the base in this way, there is a risk that the fixture may separate from the base and fall.

## Quick-mount surface mounting bracket

Quick-mount surface mounting brackets for the MAC Aura are available from Martin in sets of five that include hardware and safety cables (P/N 91606017). The bracket can be screwed to a surface and the MAC Aura can be mounted on and removed from the bracket in seconds.

The MAC Aura is a tight fit in the surface mounting bracket. Make sure that the fixture is securely clipped into the bracket and always secure the fixture with the safety cable supplied with the bracket.

Installation instructions are supplied with the brackets.

# Setup



**Warning!** Read “Safety Information” on page 3 before installing, powering, operating or servicing the MAC Aura.

## Control panel and menu navigation

The onboard control panel and backlit graphic display are used to set the MAC Aura’s DMX address, configure individual fixture settings, read out data and execute service utilities. See “Onboard control menus” on page 29 for a complete list of menus and commands.

Some of the commands available in the control panel are also available on-the-fly via DMX on channel 8, the fixture control channel. See channel 8 under “DMX protocol” on page 22 for a list of the commands available.

### Using the control buttons

- To enter a menu, select a function or apply a selection, press **▶** (Enter).
- Press **▲** (Up) and **▼** (Down) to scroll within a menu or adjust values.
- To escape a function or move back one level in the menu structure, press **◀** (Menu / Escape).

### Control button reset shortcut

- Holding **◀** (Menu/Escape) pressed in and pressing **▲** (Up) forces the fixture to reset.

### Display panel functions

The DMX address is shown in the display panel when the MAC Aura is powered on and has reset.

The display panel backlighting indicates fixture status as follows:

- The display blacks out during resets.
- The display flashes slowly if the fixture is not receiving a valid DMX signal unless the control buttons are used. In this case, the display behaves normally until the buttons have not been used for a short period, then begins to flash slowly again.
- The display can be set to go into sleep mode via **PERSONALITY** → **DISPLAY** in the control menu. Connecting a DMX signal ‘wakes up’ the display.

## DMX address setting

The DMX address, also known as the start channel, is the first channel used to receive instructions from the controller. For independent control, each fixture must be assigned its own control channels. Two MAC Aura fixtures of the same type may share the same address, however, if identical behavior is desired. Address sharing can be useful for diagnostic purposes and symmetric control, particularly when combined with the inverse pan and tilt options.

The DMX address is configured using the **DMX ADDRESS** menu in the control panel.

## Beam, Aura and FX control

### STD and EXT modes

DMX control mode is selected in the **CONTROL MODE** menu. The MAC Aura has two DMX control modes:

- **STD** (standard mode – uses 14 DMX channels)
- **EXT** (extended mode – uses 25 DMX channels).

### Standard mode

When the MAC Aura is set to **STD** standard mode, the Beam DMX channels 1 - 14 control the output of both the Beam and the Aura. The behavior of the Beam and Aura are identical.

### Extended mode

When the MAC Aura is set to **EXT** extended mode:

- Independent control of the Beam is available on channels 1 - 14
- A range of FX (pre-programmed effects with combined Beam and Aura output) is available on channels 15 - 19
- Independent control of the Aura is available on channels 20 - 25.

See "DMX protocol" on page 22 for details of the DMX commands available in the different modes.

## Recommended Beam and Aura control method

Operating the MAC Aura in **EXT** mode will give full access to the fixture's effects. Depending on the type of console used and the intended precision of control, we recommend that you consider creating console libraries for the Beam and Aura either separately or in combined multi-part fixtures. Your console's user documentation should give details of how it handles multi-part fixtures.

Separating Beam and Aura in this way may also be useful for pixel mapping applications where only the Aura is controlled by a media server.

For each device, a Beam and Aura 'fixture' will need to be patched consecutively.

### Suggested setup

**Beam:** Use channels 1 through 19.

Beam provides control of all parameters for the main Beam and the FX section.

**Aura:** Use channels 20 through 26.

Aura provides intensity, strobe and color control for the Aura array. Certain FX require Aura intensity to be above 0% to be visible. Please consult the FX documentation available on [www.martin.com](http://www.martin.com) for more details.

## Tailoring performance

### Pan and tilt movement

The **P/T SPEED** settings set the maximum speed of pan and tilt movement. **FAST** optimizes for speed and **SLOW** optimizes for smoothness of movement. **NORMAL** is a compromise between these two. The default setting is **FAST**.

The **PAN INVERT** and **TILT INVERT** commands reverse the direction of pan and tilt, and the **SWAP** command sends pan commands to tilt and vice versa. These settings are useful for symmetrical effects with multiple fixtures.

### Cooling

**FANS** gives you a choice of two settings:

- The default setting **REGULATED** should suit use in all normal situations and ensure excellent service lifetimes for all components.
- **FULL** maximizes cooling and reduces the operating temperature of the components in the head. It is recommended when the MAC Aura is used intensively in a warm environment or in fixed installations. Note that it will give increased fan noise compared to the other cooling modes.

Whatever cooling mode is selected, a thermal cutout shuts down power to the LEDs if the fixture temperature exceeds safe limits. If this occurs, you must reset the fixture via the control menus or via DMX, or cycle power to the fixture off and on again.

If a thermal shutdown occurs, you are pushing the fixture to its limits. Clean the fixture, particularly the air vents, and check that there is sufficient airflow around the fixture. Consider increasing ventilation, reducing the ambient temperature, or switching to **FULL** mode. Contact Martin for service if a thermal shutdown persists.

## Dimming

**DIMMER CURVE** provides four dimming options (see Figure 3):

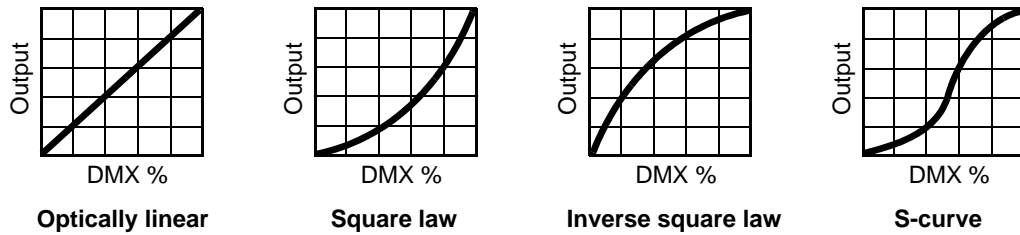

**Figure 3: Dimming curve options**

- **LINEAR** – the increase in light intensity appears to be linear as DMX value is increased.
- **SQUARE LAW** – light intensity control is finer at low levels and coarser at high levels.
- **INVERSE SQUARE LAW** – light intensity control is coarser at low levels and finer at high levels.
- **S-CURVE** – light intensity control is finer at low levels and high levels and coarser at medium levels.

Whichever **DIMMER CURVE** option you select, you can choose between **FAST** or **SMOOTH** dimming settings:

- **FAST** is the default setting. It gives a virtually instantaneous reaction when you dim from one intensity to another, but dimming slowly from one intensity to another may appear slightly uneven.
- The **SMOOTH** setting gives smoother dimming during slow changes in intensity, but it limits the speed of dimming changes slightly. This makes it ideal for slow, smooth dimming, but a short time-lag may be noticeable if you try to dim quickly from one intensity to another.

## Restoring factory default settings

The MAC Aura factory default settings can be restored by applying a **FACTORY DEFAULT** → **LOAD** command.

# Operation and effects



**Warning!** Read “Safety Information” starting on page 3 before installing, powering, operating or servicing the MAC Aura.

See “DMX protocol” on page 22 for a full list of the DMX channels and values required to control the different effects.

## Effects

### Beam and Aura

The MAC Aura has two LED arrays:

- The **Beam**: the LEDs that provide the main output, and
- The **Aura**: the secondary LEDs that illuminate the front of the head, provide local diffuse light output and can be set to contrast with the Beam output.

See “Beam, Aura and FX control” on page 13 for full details of these modes and how to set them up.

### Shutter effect

The electronic ‘shutter’ effect available for the Beam and the Aura provides instant open and blackout, variable speed regular and random strobe and opening/closing pulse effects as well as burst and sine wave effects.

### Dimming

Beam and Aura intensity can be adjusted 0 - 100% using electronic dimming. See the available dimming curve options in “Dimming” on page 15.

### Zoom

The Beam can be zoomed from 58° to maximum (narrow) 11° one-tenth peak angles.

Aura output is automatically dimmed as the zoom approaches maximum. There is a linear dimming curve from normal Aura output when the Beam is at 90% zoom, to zero Aura output when the Beam is at maximum (narrow) zoom.

### Pan and tilt

The MAC Aura’s moving head can be panned through 540° and tilted through 232°. The speed of pan/tilt movement can be adjusted on the DMX fixture control channel 8 and in the fixture’s onboard control panel.

Both **EXT** and **STD** control modes offer fine control of pan and tilt. In each case, the main control channel sets the first 8 bits (the most significant byte or MSB), and the fine channel sets the second 8 bits (the least significant byte or LSB) of the 16-bit control byte. In other words, the fine channel works within the position set by the main channel.

### Controlling color

#### Color wheel effects

The electronic ‘color wheel’ effects available for the Beam and the Aura give the convenience and feel of a mechanical color wheel and let you snap between 33 different full LEE-referenced colors. You can also scroll continuously forwards or backwards through the colors or display random colors at variable speed.

The approximate RGB equivalents of the ‘color wheel’ colors are given in “LEE colors and RGB equivalents” on page 28.



### Color wheel priority

The color wheel effect channels for the Beam and Aura have priority and override any color set on the Beam RGBW channels or on the Aura RGB channels. To use the RGBW and RGB channels, you must set the color wheel effect channel for Beam or Aura respectively to a DMX value from 000 - 009. If you set either color wheel channel to a DMX value above 009, the color wheel effect overrides RGBW or RGB control.

### RGBW and RGB control

RGBW (in raw mode) or RGB (in calibrated mode) color control is available for the Beam and RGB control is available for the Aura.

### CTC (Color Temperature Control)

CTC is available for the Beam on the CTC channel 14. Setting this channel to DMX value 20 or above allows you to adjust the Beam's overall color temperature, i.e. the color that has been set using the color wheel channel or the RGBW channels. Note that the more saturated the color, the less it will be affected by adjustments in color temperature. The biggest CTC variation is available when displaying white.

Overall color temperature can be varied from 10 000 - 2500 K. The default color temperature is 5600 K.

### Calibrated and raw color output

All color control modes are available in calibrated or raw modes using the command **COLOR CALIB** → **ON/OFF** in the main menu:

- **COLOR CALIB** → **ON** is the calibrated mode. It gives slightly reduced LED power but sets LEDs to their factory-calibrated output power to give the best-matched color and white output across multiple fixtures.  
In calibrated mode, the Beam has color wheel and RGB options available. In RGB control, the Beam's white LED control channel has no effect. White output is added to the Beam's calibrated RGB output automatically as required to increase intensity and reduce color saturation. Setting all three colors to 100% intensity gives 100% intensity white, with the white LEDs at their calibrated maximum.
- **COLOR CALIB** → **OFF** is the raw mode. It allows all LEDs to be operated to their absolute maximum output regardless of color calibration issues, so color and white output can vary slightly between fixtures.  
In raw mode, the Beam has color wheel effect and RGBW options available. In RGBW control, the Beam's white LED control channel must be used to manually control white output in RGBW color mixing.

### FX: pre-programmed Beam and Aura effects

A library of pre-programmed effects in which Beam and Aura output can be independent or synchronized is available via DMX. These effects are simply called **FX** in this manual and in the fixture menus. The library is available twice in the DMX channel layout with identical functions and effects, and two different FX can be combined and run simultaneously with one 'superimposed' over the other.

See "FX: pre-programmed effects" on page 27 for an overview of the FX available. The MAC Aura Product Support page on [www.martin.com](http://www.martin.com) features a downloadable detailed description of the parameters adjusted and algorithms applied in the different FX.

Effects are selected using the **FX select** DMX channels 15 and 17. Where modification is possible, the selected FX can be modified using its **FX adjust** channel. Modifications can include speed, amount, offset, smoothness, etc. depending on the FX selected.

### FX Sync and Random operation

The FX system uses a dedicated internal synchronization clock. If two different FX that repeat in cycles are activated, the **FX Sync** DMX channel 19 can be used to synchronize them. When two FX are synchronized, the repeat cycle of FX2 is adjusted to ensure that FX2 arrives at the end of a cycle and starts to repeat the cycle at the same time as FX1.

If one FX with a short repeat cycle is combined with another FX with a long repeat cycle, the short FX can repeat twice or more in the time it takes the long FX to repeat once. But if two FX with different repeat cycles are synchronized, the short cycle is adjusted so that it arrives at the end of a cycle at the same time as the long cycle.

#### **Sync shift**

The **sync shift** option modifies FX synchronization so that FX2 runs with a time offset. This means that the FX2 cycle start point is delayed relative to FX1, but the amount of the delay remains constant.

#### **Random operation**

Selecting random operation makes random changes in the duration of those FX effects that have repeat cycles. This means that some cycles are shorter and some cycles are longer in a random pattern.

The **random sync** option changes the duration of FX repeat cycles in a random pattern. Cycle duration is random, but it is always changed by the same amount for FX1 and FX2 so that FX remain synchronized. The overall speed of this synchronized effect is controlled on channel 16.

The **random no sync** option changes the duration of FX effect cycles in a random pattern, and FX1 and FX2 are not synchronized. The speed of FX1 and FX2 effects are controlled independently on channels 16 and 18 respectively.

#### **FX priority and overriding**

If an FX is activated, it overrides any other settings for the parameters that the FX modifies. For example, an FX that modifies the zoom will override any zoom angle set on the zoom channel (DMX channel 3).

If the same FX is selected on both the **FX1 select** and **FX2 select** channels, only the **FX1 adjust** channel is active. The **FX2 adjust** channel is ignored.

If different FX are selected on the **FX1 select** and **FX2 select** channels, FX2 is superimposed onto FX1 and FX2 overrides FX1 whenever both FX modify the same parameter.

## **RDM**

RDM (Remote Device Management) is implemented in the MAC Aura and RDM communication is possible over the DMX data link. As provided for in the ANSI/ESTA E1.20 RDM protocol, the fixture can send information about its RDM-accessible parameters to an RDM control device.

# Service and maintenance



**Warning!** Read “Safety Information” on page 3 before servicing the MAC Aura.

**Warning!** Disconnect the fixture from AC mains power and allow to cool for at least 10 minutes before handling. Do not view the light output from less than 8.3 meters (27 ft. 3 inches) without shade 4-5 welding goggles. Be prepared for the fixture to light suddenly if connected to power.



**Warning!** Refer any service operation not described in this user manual to a qualified service technician.



**Important!** Excessive dust, smoke fluid, and particle buildup degrades performance, causes overheating and will damage the fixture. Damage caused by inadequate cleaning or maintenance is not covered by the product warranty.



The user will need to clean the MAC Aura periodically, and it is also possible for the user to update the firmware and install the optional diffuser accessory available from Martin. All other service operations on the MAC Aura must be carried out by Martin Professional or its approved service agents.

Installation, on-site service and maintenance can be provided worldwide by the Martin Professional Global Service organization and its approved agents, giving owners access to Martin’s expertise and product knowledge in a partnership that will ensure the highest level of performance throughout the product’s lifetime. Please contact your Martin supplier for details.

It is Martin policy to apply the strictest possible calibration procedures and use the best quality materials available to ensure optimum performance and the longest possible component lifetimes. However, LEDs are subject to wear and tear over the life of the product, resulting in gradual changes in color and overall brightness over many thousands of hours of use. The extent of wear and tear depends heavily on operating conditions and environment, so it is impossible to specify precisely whether and to what extent LED performance will be affected. However, you may eventually need to ask Martin Professional to replace LEDs if their characteristics are affected by wear and tear after an extended period of use and if you require fixtures to perform within very precise optical and color parameters.

The manufacturer’s LED lifetime data is based on performance under the manufacturer’s test conditions. As with all LEDs, the gradual reduction in luminous output will be accelerated when LEDs are used in a fixture, where conditions are much tougher than in manufacturer’s testing. To maximize LED lifetimes, keep the ambient temperature as low as possible and drive the LEDs no harder and for no longer than necessary.

## Cleaning

Cleaning schedules for lighting fixtures vary greatly depending on the operating environment. It is therefore impossible to specify precise cleaning intervals for the MAC Aura. Environmental factors that may result in a need for frequent cleaning include:

- Use of smoke or fog machines.
- High airflow rates (near air conditioning vents, for example).
- Presence of cigarette smoke.
- Airborne dust (from stage effects, building structures and fittings or the natural environment at outdoor events, for example).

If one or more of these factors is present, inspect fixtures within their first 100 hours of operation to see whether cleaning is necessary. Check again at frequent intervals. This procedure will allow you to assess cleaning requirements in your particular situation. If in doubt, consult your Martin dealer about a suitable maintenance schedule.

Use gentle pressure only when cleaning, and work in a clean, well-lit area. Do not use any product that contains solvents or abrasives, as these can cause surface damage.

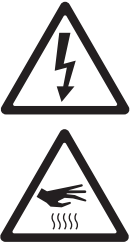

**Warning! Disconnect from power and allow to cool before cleaning.**

To clean the fixture:

1. Disconnect the fixture from power and allow it to cool for at least 10 minutes.
2. Vacuum or gently blow away dust and loose particles from the outside of the fixture and the air vents at the back and sides of the head and in the base with low-pressure compressed air.
3. Clean the LED lens array in the front of the head by wiping gently with a soft, clean lint-free cloth moistened with a weak detergent solution. Do not rub the surface hard: lift particles off with a soft repeated press. Dry with a soft, clean, lint-free cloth or low-pressure compressed air. Remove stuck particles with an unscented tissue or cotton swab moistened with glass cleaner or distilled water.
4. Check that the fixture is dry before reapplying power.

## Control menu service utilities

### Functions test

The **TEST** feature provides four test routines that can be executed without a controller, allowing testing of pan/tilt and zoom, LEDs and display separately or together.

### Pan and tilt calibration

Pan and tilt on the MAC Aura are calibrated at the factory so that movement is identical in multiple fixtures. Adjustment should not be necessary initially, but over a period of use fixtures may gradually lose calibration. If re-calibration is necessary:

1. Pan calibration is easiest when multiple fixtures are stacked vertically. To calibrate, set tilt positions for easy one-over-the-other comparison and set each fixture to the same pan DMX value. Select one fixture to be the reference fixture. On that fixture, select **SERVICE** → **CALIBRATION** → **PAN OFFSET** and press **▶**. Wait for the fixture to move to its pan calibration position.
2. On each of the other fixtures, select **SERVICE** → **CALIBRATION** → **PAN OFFSET** and press **▶**. Wait for the head to move to the pan calibration position, then adjust the pan offset using the **▲** and **▼** buttons as necessary to align the beam with the reference beam. Press **▶** to save the setting, then **◀** to exit.
3. Tilt calibration is easiest when multiple fixtures are arranged side-by-side horizontally. To calibrate, set pan positions for easy side-by-side comparison. Select one fixture to be the reference fixture. On that fixture, select **SERVICE** → **CALIBRATION** → **TILT OFFSET** and press **▶**. Wait for the fixture to move to its tilt calibration position.
4. On each of the other fixtures, select **SERVICE** → **CALIBRATION** → **TILT OFFSET** and press **▶**. Wait for the head to move to the tilt calibration position, then adjust the tilt offset using the **▲** and **▼** buttons as necessary to align the beam with the reference beam. Press **▶** to save the setting, then **◀** to exit.

### Software upload

The MAC Aura is loaded with both software (that can be installed and updated by the user) and firmware (that is internal and accessible to Martin Service and its authorized partners only). Software updates are available from the Martin website and can be installed with a PC and Martin USB Duo DMX Interface box that can upload software to one fixture at a time.

The following are required in order to install software:

- The latest version of the MAC Aura software, available for download free of charge from the Product Support area of the Martin website at <http://www.martin.com>
- A PC running Windows 7 and Vista 32/64-bit and Windows XP SP3 32-bit
- The Windows-based Martin Uploader application available for download free of charge from the Downloads Area of the Martin website at <http://www.martin.com>
- Martin USB Duo DMX Interface Box with its supplied cables.

#### Installing software: normal method

1. Connect the Uploader hardware to a MAC Aura fixture's data input connector.
2. Upload the fixture software as described in the uploader's help file or user documentation.
3. Disconnect the Uploader hardware and reconnect the fixture to the DMX link.
4. Cycle power off and on. Check that the fixture resets correctly. If an error message appears in the display, cycle power off and on again and check that the fixture now resets correctly.

## Fixture readouts

### DMX input signal

The **DMX LIVE** menu lets you view the DMX values received on each channel in the mode – **STD** or **EXT** – it is currently set to. If the fixture does not behave as expected, reading the DMX values can help you troubleshoot the problem.

### Fixture status

The MAC Aura gives fixture status readouts in the **INFO** menu:

- Current software/firmware version information.
- Temperature readouts from the main PCB as well as the Beam LED and Aura LED PCBs. In each case, you can view the current temperature and the maximum temperature reached since the readout was last reset. The maximum temperatures can be reset individually. The **MAX** temperature counters are not resettable.
- Power on hours. You can view the number of hours since the resettable counter was last reset or the total number of hours since manufacture. You can also reset the resettable counter to zero.
- The manufacturer's serial number and the fixture's RDM ID number.

### Display messages

If an error occurs, the MAC Aura gives fixture status readouts in the display. See "Display messages" on page 31.

## Lubrication

In general, the MAC Aura does not require lubrication. However, depending on use conditions, the moving parts in the pan and tilt mechanisms may eventually require reapplication of lubricant. Excessive noise during pan/tilt movement is a sign that lubrication may be required. This operation can be carried out by a Martin service partner if necessary.

# DMX protocol

Channel		DMX	Percent	Function	Fade	Default
Std.	Ext.	value			status	value
1		0 - 19	0 - 7	<b>Beam electronic shutter effect</b> Shutter closed	Snap	22
		20 - 24	8 - 9	Shutter open		
		25 - 64	10 - 25	Strobe 1 (fast → slow)		
		65 - 69	26 - 27	Shutter open		
		70 - 84	28 - 33	Strobe 2: opening pulse (fast → slow)		
		85 - 89	34 - 35	Shutter open		
		90 - 104	36 - 41	Strobe 3: closing pulse (fast → slow)		
		105 - 109	42 - 43	Shutter open		
		110 - 124	44 - 49	Strobe 4: random strobe (fast → slow)		
		125 - 129	50 - 51	Shutter open		
		130 - 144	52 - 57	Strobe 5: random opening pulse (fast → slow)		
		145 - 149	58 - 59	Shutter open		
		150 - 164	60 - 65	Strobe 6: random closing pulse (fast → slow)		
		165 - 169	66 - 67	Shutter open		
		170 - 184	68 - 73	Strobe 7: burst pulse (fast → slow)		
		185 - 189	74 - 75	Shutter open		
		190 - 204	76 - 81	Strobe 8: random burst pulse (fast → slow)		
		205 - 209	82 - 83	Shutter open		
		210 - 224	84 - 89	Strobe 9: sine wave (fast → slow)		
		225 - 229	90 - 91	Shutter open		
	230 - 244	92 - 97	Strobe 10: burst (fast → slow)			
	245 - 255	98 - 100	Shutter open			
2		0 - 255	0 - 100	<b>Beam dimmer</b> 0 → 100% intensity	Fade	0
3		0 - 255	0 - 100	<b>Zoom</b> Wide → narrow	Fade	255
4		0 - 255	0 - 100	<b>Pan</b> Left → right	Fade	128
5		0 - 255	0 - 100	<b>Pan fine</b> Pan fine adjustment (Least Significant Byte)	Fade	32768
6		0 - 255	0 - 100	<b>Tilt</b> Tilt 0 - 232°	Fade	128
7		0 - 255	0 - 100	<b>Tilt fine</b> Tilt fine adjustment (Least Significant Byte)	Fade	32768

Table 2: MAC Aura DMX Protocol

Channel		DMX value	Percent	Function	Fade status	Default value
Std.	Ext.					
8		0 - 9	0 - 3	<b>Fixture control settings</b> <i>No function</i>	Snap	0
		10 - 14	4 - 5	Reset entire fixture <sup>1</sup>		
		15 - 39	6 - 13	<i>No function</i>		
		40 - 44	14 - 15	PTSP = NORM <sup>2</sup>		
		45 - 49	16 - 17	PTSP = FAST <sup>2</sup>		
		50 - 54	18 - 19	PTSP = SLOW <sup>2</sup>		
		55 - 59	20 - 21	<i>No function</i>		
		60 - 64	22 - 23	Fan mode FULL <sup>2</sup>		
		65 - 69	24 - 25	<i>No function</i>		
		70 - 74	26 - 27	Fan mode REGULATED <sup>2</sup>		
		75 - 89	28 - 33	<i>No function</i>		
		90 - 94	34 - 35	Calibrated color output mode COLOR CALIB = ON <sup>3</sup>		
		95 - 99	36 - 37	<i>No function</i>		
		100 - 104	38 - 40	Raw color output mode COLOR CALIB = OFF <sup>3</sup>		
		105 - 109	41 - 42	<i>No function</i>		
		110 - 114	43 - 44	Fast dimming, speed of changes unrestricted <sup>2</sup>		
		115 - 119	45 - 46	<i>No function</i>		
		120 - 124	47 - 48	Smooth dimming, speed of changes restricted slightly <sup>2</sup>		
	125 - 249	49 - 97	<i>No function</i>			
	250 - 255	98 - 100	Illuminate display			
				<sup>1</sup> If DMX Reset is disabled in the menu, a reset command can only be executed if channel 2 is set to 232 and channel 1 is set to zero. These values need to be held for 5 seconds before feature is activated. Values must be "snapped to" to function.		
				<sup>2</sup> Menu override: setting unaffected by power off/on.		
				<sup>3</sup> Value must be held for 3 seconds to activate. Setting unaffected by power off/on.		

**Table 2: MAC Aura DMX Protocol**

Channel		DMX	Percent	Function	Fade	Default
Std.	Ext.	value			status	value
	<b>9</b>	0 - 9 10 - 14 15 - 19 20 - 24 25 - 29 30 - 34 35 - 39 40 - 44 45 - 49 50 - 54 55 - 59 60 - 64 65 - 69 70 - 74 75 - 79 80 - 84 85 - 89 90 - 94 95 - 99 100 - 104 105 - 109 110 - 114 115 - 119 120 - 124 125 - 129 130 - 134 135 - 139 140 - 144 145 - 149 150 - 154 155 - 159 160 - 164 165 - 169 170 - 174 175 - 179  180 - 201 202 - 207 208 - 229 230 - 234  235 - 239 240 - 244 245 - 249 250 - 255	0 - 2 3 - 4 4 - 5 6 - 7 8 - 9 10 - 11 12 - 13 14 - 15 16 - 17 18 - 19 20 - 21 22 - 23 24 - 25 26 - 27 28 - 29 30 - 31 32 - 33 34 - 35 36 - 37 38 - 39 40 - 41 42 - 43 44 - 45 46 - 47 48 - 49 50 - 51 52 - 53 54 - 55 56 - 57 58 - 59 60 - 61 62 - 63 64 - 65 66 - 67 68 - 69  70 - 78 79 - 80 81 - 89 90 - 91  92 - 93 94 - 95 96 - 97 98 - 100	<b>Beam color wheel effect</b> Open. RGBW color mixing enabled LEE 790 - Moroccan pink LEE 157 - Pink LEE 332 - Special rose pink LEE 328 - Follies pink LEE 345 - Fuchsia pink LEE 194 - Surprise pink LEE 181 - Congo Blue LEE 071 - Tokyo Blue LEE 120 - Deep Blue LEE 079 - Just Blue LEE 132 - Medium Blue LEE 200 - Double CT Blue LEE 161 - Slate Blue LEE 201 - Full CT Blue LEE 202 - Half CT Blue LEE 117 - Steel Blue LEE 353 - Lighter Blue LEE 118 - Light Blue LEE 116 - Medium Blue Green LEE 124 - Dark Green LEE 139 - Primary Green LEE 089 - Moss Green LEE 122 - Fern Green LEE 738 - JAS Green LEE 088 - Lime Green LEE 100 - Spring Yellow LEE 104 - Deep Amber LEE 179 - Chrome Orange LEE 105 - Orange LEE 021 - Gold Amber LEE 778 - Millennium Gold LEE 135 - Deep Golden Amber LEE 164 - Flame Red Open <b>Color wheel rotation effect</b> Clockwise, fast → slow Stop (this will stop wherever the color is at the time) Counter-clockwise, slow → fast Open <b>Random color</b> Fast Medium Slow Open	Snap	0
<b>10</b>		0 - 255	0 - 100	<b>Beam red</b> Red 0 → 100%	Fade	255
<b>11</b>		0 - 255	0 - 100	<b>Beam green</b> Green 0 → 100%	Fade	255
<b>12</b>		0 - 255	0 - 100	<b>Beam blue</b> Blue 0 → 100%	Fade	255
<b>13</b>		0 - 255	0 - 100	<b>Beam white</b> White 0 → 100% <i>Note: if <b>Color Calib</b> is set to <b>On</b>, this channel has no effect – white LEDs are activated by RGB mixing</i>	Fade	0
<b>14</b>		0 - 19 20 - 255	0 - 7 8 - 100	<b>Beam CTC</b> No Function Color temperature control 10 000K → 2 500K	Fade	255
-	<b>15</b>	0 - 255	0 - 100	<b>FX1 select</b> Pre-programmed effect 1 selection (see "FX: pre-programmed effects" on page 27)	Snap	0
-	<b>16</b>	0 - 255	0 - 100	<b>FX1 adjust, sync speed adjust</b> Zero → maximum • If no sync set on channel 19, adjusts FX1 • If sync set on channel 19, adjusts synchronized FX1+FX2 speed	Fade	128
-	<b>17</b>	0 - 255	0 - 100	<b>FX2 select</b> Pre-programmed effect 2 selection (see "FX: pre-programmed effects" on page 27)	Snap	0

Table 2: MAC Aura DMX Protocol



Channel		DMX value	Percent	Function	Fade status	Default value
Std.	Ext.					
-	18	0 - 255	0 - 100	<b>FX2 adjust</b> Zero → maximum • If no sync set on channel 19, adjusts FX2 • If sync set on channel 19, has no effect	Fade	128
-	19	0 - 49	0 - 19	<b>Sync (FX synchronization)</b> No sync • FX1 and FX2 run through cycles independently • Cycle duration is regular • Channel 16 and channel 18 adjust FX1 and FX2 independently Sync • FX1 and FX2 run through cycles in sync • Cycle duration is regular • Channel 16 adjusts overall speed, channel 18 has no effect Sync shift • FX1 and FX2 run through cycles in sync • FX2 is offset (delayed) relative to FX1 • Offset is adjustable from zero → maximum • Channel 16 adjusts overall speed, channel 18 has no effect Sync random • FX1 and FX2 run through cycles in sync • Cycle duration for synchronized FX1 and FX2 is made shorter and longer at random. • Channel 16 adjusts overall speed, channel 18 has no effect No sync, random • FX1 and FX2 run through cycles independently • Cycle duration is for FX1 and FX2 is made shorter and longer at random • Channel 16 and channel 18 adjust FX1 and FX2 speed independently	Snap	0
		50	20			
		51 - 169	21 - 66			
		170 - 209	67 - 81			
		210 - 255	82 - 100			

### Aura control

-	20	0 - 19 20 - 24 25 - 64 65 - 69 70 - 84 85 - 89 90 - 104 105 - 109 110 - 124 125 - 129 130 - 144 145 - 149 150 - 164 165 - 169 170 - 184 185 - 189 190 - 204 205 - 209 210 - 224 225 - 229 230 - 244 245 - 255	0 - 7 8 - 9 10 - 25 26 - 27 28 - 33 34 - 35 36 - 41 42 - 43 44 - 49 50 - 51 52 - 57 58 - 59 60 - 65 66 - 67 68 - 73 74 - 75 76 - 81 82 - 83 84 - 89 90 - 91 92 - 97 98 - 100	<b>Aura shutter and strobe effect</b> Shutter closed Shutter open Strobe 1 (fast → slow) Shutter open Strobe 2: opening pulse (fast → slow) Shutter open Strobe 3: closing pulse (fast → slow) Shutter open Strobe 4: random strobe (fast → slow) Shutter open Strobe 5: random opening pulse (fast → slow) Shutter open Strobe 6: random closing pulse (fast → slow) Shutter open Strobe 7: burst pulse (fast → slow) Shutter open Strobe 8: random burst pulse (fast → slow) Shutter open Strobe 9: sine wave (fast → slow) Shutter open Strobe 10: burst (fast → slow) Shutter open	Snap	22
-	21	0 - 255	0 - 100	<b>Aura dimmer</b> 0 → 100% intensity	Fade	0

Table 2: MAC Aura DMX Protocol

Channel		DMX value	Percent	Function	Fade status	Default value
Std.	Ext.					
-	22	0 - 9 10 - 14 15 - 19 20 - 24 25 - 29 30 - 34 35 - 39 40 - 44 45 - 49 50 - 54 55 - 59 60 - 64 65 - 69 70 - 74 75 - 79 80 - 84 85 - 89 90 - 94 95 - 99 100 - 104 105 - 109 110 - 114 115 - 119 120 - 124 125 - 129 130 - 134 135 - 139 140 - 144 145 - 149 150 - 154 155 - 159 160 - 164 165 - 169 170 - 174 175 - 179  180 - 201 202 - 207 208 - 229 230 - 234  235 - 239 240 - 244 245 - 249 250 - 255	0 - 1 2 - 3 4 - 5 6 - 7 8 - 9 10 - 11 12 - 13 14 - 15 16 - 17 18 - 19 20 - 21 22 - 23 24 - 25 26 - 27 28 - 29 30 - 31 32 - 33 34 - 35 36 - 37 38 - 39 40 - 41 42 - 43 44 - 45 46 - 47 48 - 49 50 - 51 52 - 53 54 - 55 56 - 57 58 - 59 60 - 61 62 - 63 64 - 65 66 - 67 68 - 69  70 - 78 79 - 80 81 - 89 90 - 91  92 - 93 94 - 95 96 - 97 98 - 100	<b>Aura color wheel effect</b> Open. RGB color mixing enabled LEE 790 - Moroccan pink LEE 157 - Pink LEE 332 - Special rose pink LEE 328 - Follies pink LEE 345 - Fuchsia pink LEE 194 - Surprise pink LEE 181 - Congo Blue LEE 071 - Tokyo Blue LEE 120 - Deep Blue LEE 079 - Just Blue LEE 132 - Medium Blue LEE 200 - Double CT Blue LEE 161 - Slate Blue LEE 201 - Full CT Blue LEE 202 - Half CT Blue LEE 117 - Steel Blue LEE 353 - Lighter Blue LEE 118 - Light Blue LEE 116 - Medium Blue Green LEE 124 - Dark Green LEE 139 - Primary Green LEE 089 - Moss Green LEE 122 - Fern Green LEE 738 - JAS Green LEE 088 - Lime Green LEE 100 - Spring Yellow LEE 104 - Deep Amber LEE 179 - Chrome Orange LEE 105 - Orange LEE 021 - Gold Amber LEE 778 - Millennium Gold LEE 135 - Deep Golden Amber LEE 164 - Flame Red Open <b>Color wheel rotation effect</b> Clockwise, fast → slow Stop (this will stop wherever the color is at the time) Counter-clockwise, slow → fast Open <b>Random color</b> Fast Medium Slow Open	Snap	0
-	23	0 - 255	0 - 100	<b>Aura red</b> Red 0 → 100%	Fade	255
-	24	0 - 255	0 - 100	<b>Aura green</b> Green 0 → 100%	Fade	255
-	25	0 - 255	0 - 100	<b>Aura blue</b> Blue 0 → 100%	Fade	255

Table 2: MAC Aura DMX Protocol

Note: DMX values labeled "No function" will have no effect - the last functional value will be used.  
If **COLOR CALIB** is set to **OFF** in the control menus, RGBW, RGB and color wheel effect output is uncalibrated. If **COLOR CALIB** is set to **ON**, output is calibrated.

# FX: pre-programmed effects

The table below lists the pre-programmed effects that can be selected on DMX channels 15 and 17. Two effects can be superimposed by selecting one effect on channel 15 and a different effect on channel 17.

Type	DMX value	Percent	FX Name	FX Adjust
<b>Aura Sync</b>	0 - 9	0 - 3	<b>Dimmer sync</b> Idle	n/a
	10 - 12	4	Dimmer sync	n/a
	13 - 15	5	Strobe sync	n/a
	16 - 18	6 - 7	Dimmer + strobe sync	n/a
	19 - 21	8	Aura color sync	n/a
	22 - 24	9	Aura all sync	n/a
	25 - 39	10 - 15	<i>Reserved</i>	n/a
	<b>Intensity FX</b>	40 - 42	16	<b>Aura strobe delay</b> Aura strobe delay
43 - 45		17	Strobe alternate single	Speed
46 - 48		18	Strobe alternate dual	Speed
49 - 51		19 - 20	Strobe alternate triple	Speed
52 - 54		21	3-step strobe	Speed
55 - 60		22 - 23	<i>Reserved</i>	n/a
61 - 63		24	Intensity random alternate	Speed
64 - 66		25	Aura ramp, Beam flash	Speed
67 - 69		26 - 27	Beam ramp, Aura flash	Speed
70 - 72		28	Intensity Aura, Beam ramp	Speed
73 - 75		29	Intensity Beam, Aura ramp	Speed
76 - 99		30 - 38	<i>Reserved</i>	n/a
<b>Color FX</b>		100 - 102	39	<b>Aura color offset</b> Aura color offset
	103 - 108	40 - 42	<i>Reserved</i>	n/a
	109 - 111	43	Hue shimmer	Amount
	112 - 114	44	Saturation shimmer	Amount
	115 - 126	45 - 49	<i>Reserved</i>	n/a
	127 - 129	50	Color strobe	n/a
	130 - 132	51	Color offset strobe	Color offset on strobe
	133 - 135	52	Aura color strobe	n/a
	136 - 138	53	Aura color offset strobe	Aura color offset on strobe
	139 - 141	54 - 55	Color spikes	Strength
	142 - 159	56 - 62	<i>Reserved</i>	n/a
<b>Zoom FX</b>	160 - 162	63	<b>Zoom / color offset</b> Color zoom ramp in	Speed
	163 - 165	64	Color zoom ramp out	Speed
	166 - 168	65	Color zoom fade in	Speed
	169 - 171	66	Color zoom fade out	Speed
	172 - 174	67 - 68	<i>Reserved</i>	n/a
	175 - 177	69	Zoom ramp up	Speed
	178 - 180	70	Zoom ramp down	Speed
	181 - 219	71 - 85	<i>Reserved</i>	n/a
<i>Reserved</i>	220 - 255	86 - 100	<i>Reserved</i>	n/a

**Table 3: FX (pre-programmed Beam and Aura effects)**

The MAC Aura Product Support page on [www.martin.com](http://www.martin.com) features a downloadable detailed description of the parameters that are adjusted and algorithms that are applied in the different FX.

# LEE colors and RGB equivalents

The table below gives approximate RGB equivalents for the LEE colors available in the standard MAC Aura's color wheel effects for the Beam (on DMX channel 9 in **STD** and **EXT** modes) and Aura (on DMX channel 22 in **EXT** mode only).

Lee no.	Name	DMX Integer		
		Red	Green	Blue
790	Moroccan Pink	255	235	052
157	Pink	214	134	048
332	Special rose Pink	255	000	044
328	Follies Pink	255	059	113
345	Fuchsia Pink	255	138	219
194	Surprise Pink	226	175	226
181	Congo Blue	040	001	255
071	Tokyo Blue	000	000	255
120	Deep Blue	000	078	255
079	Just Blue	000	199	255
132	Medium Blue	000	255	234
200	Double CT Blue	149	246	255
161	State Blue	137	255	227
201	Full CT Blue	213	220	222
202	Half CT Blue	219	232	175
117	Steel Blue	205	255	199
353	Lighter Blue	115	255	165
118	Light Blue	006	255	143
116	Medium Blue Green	000	255	94
124	Dark Green	029	255	000
139	Primary Green	032	223	000
089	Moss Green	075	255	000
122	Fern Green	080	232	000
738	JAS Green	108	226	000
088	Lime Green	145	194	000
100	Spring Yellow	210	255	000
104	Deep Amber	225	232	000
179	Chrome Orange	023	215	000
105	Orange	247	214	000
021	Gold Amber	255	163	000
778	Millennium Gold	255	152	000
135	Deep Golden Amber	255	108	000
164	Flame Red	255	080	000

# Onboard control menus

Menu	Item	Options	Notes (Default settings in bold print)
<b>DMX ADDRESS</b>		<b>1 – XXX</b>	DMX address (default address = 1). The DMX address range is limited so that the fixture will always have enough DMX channels within the 512 available.
<b>CONTROL MODE</b>	<b>STD</b>		Linked control of Beam and Aura using Beam channels, Aura copies Beam (fixture uses 14 DMX channels)
	<b>EXT</b>		<b>Independent control of Beam and Aura, FX available (fixture uses 25 DMX channels)</b>
<b>COLOR CALIB</b>	<b>ON</b>		Color calibration mode on. Independent white control not available for Beam on DMX channel 13 (white obtained by RGB dimming)
	<b>OFF</b>		<b>Color calibration mode off. White available for Beam on DMX channel 13 to give raw RGBW dimming</b>
<b>PERSONALITY</b>	<b>P/T SETTING</b>	<b>P/T SPEED</b>	Pan and tilt speed normal / <b>fast</b> / slow
		<b>SWAP</b>	Swap pan and tilt (pan commands move tilt and vice versa) - <b>off</b> / on
		<b>PAN INVERT</b>	Pan inversion (reverse direction pan control) - <b>off</b> / on
		<b>TILT INVERT</b>	Tilt inversion (reverse direction tilt control) - <b>off</b> / on
	<b>FANS</b>	<b>REGULATED</b>	<b>Cooling fan speed thermostatically regulated</b>
		<b>FULL</b>	Max. cooling fan speed
	<b>DIMMER CURVE</b>	<b>LINEAR</b>	Linear dimming curve
		<b>SQUARE LAW</b>	<b>Square law dimming curve</b>
		<b>INV SQUARE LAW</b>	Inverse square law dimming curve
		<b>S-CURVE</b>	S-curve dimming curve
	<b>DIMMER SPEED</b>	<b>FAST</b>	<b>Fast dimming with unrestricted speed</b>
		<b>SMOOTH</b>	Smooth dimming with restricted speed
	<b>DMX RESET</b>	<b>OFF</b>	Disable reset via DMX
		<b>ON</b>	<b>Enable reset via DMX</b>
	<b>DISPLAY</b>	<b>ON</b>	Display is always on
		<b>2MIN</b>	<b>Display switches off and goes into Sleep mode if the controls have not been pressed for 2 minutes.</b>
		<b>5MIN</b>	Display switches off and goes into Sleep mode if the controls have not been pressed for 5 minutes
		<b>10MIN</b>	Display switches off and goes into Sleep mode if the controls have not been pressed for 10 minutes
	<b>DISPLAY INTENSITY</b>	<b>10-100</b>	Display intensity. Default= <b>100</b>
	<b>ERROR MODE</b>	<b>NORMAL</b>	<b>Display errors at 100% intensity (regardless of DISPLAY INTENSITY setting) and illuminate the service light</b>
<b>SILENT</b>		Silent error mode. The error message does not appear in the display, but the service lamp is illuminated	
<b>FACTORY SETTING</b>	<b>FACTORY DEFAULT</b>	<b>LOAD</b>	Return all settings (except calibrations) to factory defaults <i>NB: can take up to 2 minutes to complete!</i>

Table 4: Control menu

Menu	Item	Options	Notes (Default settings in bold print)
INFO	VERSION		CPU firmware version
	POWER ON HOURS	RESETTABLE	Hours of operation since counter reset
		TOTAL	Total hours of operation since manufacture
		CLEAR RESETTABLE	Reset resettable counter to zero
	MAIN PCB TEMP	CURRENT	Display current main PCB temperature
		SINCE RESET	Display highest main PCB temperature since last reset
		MAX	Display highest main PCB temperature since manufacture
	BEAM LED TEMP	CURRENT	Display current average Beam LED temperature
		RESET	Display highest average Beam LED temperature since last reset
		MAX	Display highest average Beam LED temperature since manufacture
	AURA LED TEMP	CURRENT	Display current average Aura LED temperature
		RESET	Display highest average Aura LED temperature since last reset
		MAX	Display highest average Aura LED temperature since manufacture
SERIAL NUMBERS	RDM	Display fixture's RDM ID	
	FIXT SERIAL NUMBER	Display fixture's serial number	
TEST	TEST ALL		Test LEDs, pan, tilt, zoom and display
	TEST LEDES		Test LEDs only
	TEST MOTORS		Test pan, tilt and zoom movement only
	TEST DISPLAY		Test all segments in onboard display panel
DMX LIVE	RATE	xx Hz	DMX transmission speed, live, in packets per second
	QUALITY	0 - 100%	Percentage of packets received with errors, live
	START CODE	0 - 255	Decimal value of DMX start code, live
	BEAM SHUT - AURA BLUE	0 - 255	Scrolls through DMX value received on each DMX channel <i>DMX values received on FX and Aura control channels only appear in list when fixture is set to EXT mode</i>
SERVICE	P/T FEEDBACK	ON	<b>Enable pan/tilt position feedback/correction system</b>
		OFF	Disable pan/tilt feedback for servicing (this setting is not saved when fixture is reset)
	CALIBRATION	PAN OFFSET	Pan calibration
		TILT OFFSET	Tilt calibration

Table 4: Control menu

# Display messages

Message	Appears when...	What to do...
<b>RST</b> (Reset)	... the fixture is indexing effects at startup.	Wait for reset to complete.
<b>SRST</b> (Serial reset)	... the fixture has received a reset command.	Wait for reset to complete. Note that you can set <b>PERSONALITY</b> → <b>DMX RESET</b> to <b>OFF</b> to prevent accidental DMX reset commands.
<b>MEMORY ERROR</b>	...the EEPROM memory cannot be read.	Reset fixture. Contact Martin if problem persists.
<b>MAIN TMP SEN ERR</b> (RDM message: Head Temp. Error)	...there is a malfunction in the temperature sensor circuit in the main PCB in the head.	Contact Martin service for assistance.
<b>BEAM TMP SEN ERR</b> (RDM message: Lamp Temp. Error)	...there is a malfunction in the Beam LED temperature sensor circuit.	Contact Martin service for assistance.
<b>AURA TMP SEN ERR</b> (RDM message: Lamp Temp. Error)	...there is a malfunction in the Aura LED temperature sensor circuit.	Contact Martin service for assistance.
<b>MAIN TMP CUT OFF</b> (RDM message: Lamp Temp. Cut Off)	...the temperature sensor on the main PCB in the head measures that temperature is too high. Power to the LEDs is cut off.	Check that ambient temperature is not too high. Check that the fixture is clean. Check that there is free airflow around the fixture. Contact Martin service for assistance.
<b>BEAM TMP CUT OFF</b> (RDM message: Lamp Temp. Cut Off)	...the Beam LED temperature sensor measures that LED temperature is too high. Power to the LEDs is cut off.	
<b>AURA TMP CUT OFF</b> (RDM message: Lamp Temp. Cut Off)	...the Aura LED temperature sensor measures that LED temperature is too high. Power to the LEDs is cut off.	
<b>PAN FBACK ERR</b> <b>TILT FBACK ERR</b>	...there is a malfunction in the optical pan or tilt monitoring/feedback circuit (e.g. sensor defective). After a time-out, pan or tilt stops in a random position.	Reset fixture. Contact Martin service if problem continues.
<b>PAN SENSOR ERR</b> <b>TILT SENSOR ERR</b> <b>DRIVER CURR ERR</b>	...there is a malfunction in the electrical indexing circuit for pan, tilt or one of the drivers. After a time-out, the fixture will establish a mechanical stop, and continue to work normally.	Reset fixture. Contact Martin service if problem continues.
<b>VOLTAGE ERR</b> <b>RAM ERROR</b>	...there is a voltage or RAM error.	Reset fixture. Contact Martin service if problem continues.
<b>EFFECTS TOO COLD</b>	...the onboard thermostat measures that the effects are too cold.	Leave fixture powered on to warm it up. Contact Martin service if problem continues or fixture is warm.
<b>FAN ERROR</b>	...there is a fan or fan driver error.	Check that fan on rear of head is free to rotate freely. Contact Martin service for assistance.
<b>COLOR ERROR</b>	...there is a driver error.	Contact Martin service for assistance.
<b>BEAM CALIB ERR</b> (RDM message: Color Calibration Error 1) <b>AURA CALIB ERR</b> (RDM message: Color Calibration Error 2)	...color calibration data for Beam or Aura LEDs is invalid or there is a communication error.	Contact Martin service for assistance.

Table 5: Display messages

# Troubleshooting

<b>Problem</b>	<b>Probable cause(s)</b>	<b>Remedy</b>
Fixture is completely dead.	No power to fixture.	Check AC mains power and connections.
	Internal circuit fault.	Have faulty fixture serviced by Martin service technician.
One or more fixtures resets correctly but responds erratically or not at all to the controller.	Fault on data link.	Inspect connections and cables. Correct poor connections. Repair or replace damaged cables.
	Data link not terminated.	Insert termination plug in output connector of the last fixture on the link.
	Incorrect fixture DMX addressing.	Check addressing on fixture and controller. Check fixture is set to correct DMX mode.
	One of the fixtures is defective and is disturbing data transmission on the link.	Unplug XLR in and out connectors and connect them directly together to bypass one fixture at a time until normal operation is regained. Have faulty fixture serviced by Martin service technician.
	XLR pin-out on fixtures does not match (pins 2 and 3 reversed).	Install a phase-reversing cable between the fixtures or swap pins 2 and 3 in the fixture that behaves erratically.
Light output shuts down unexpectedly.	Fixture is too hot.	Clean the fixture, especially air vents. Ensure free airflow around fixture. Check that ambient temperature does not exceed max. permitted level. Switch to FULL cooling mode. If problem persists, contact Martin for advice.

**Table 6: Troubleshooting**



# Specifications

## Physical

Length	302 mm (11.9 in.) across yoke
Width	302 mm (11.9 in.) across yoke
Height	360 mm (14.2 in.), head straight up
Weight	5.6 kg (12.3 lbs.) without accessories

## Dynamic Effects

Beam color mixing	RGBW
Aura (secondary lens array illumination) color mixing	RGB
Beam color temperature control	CTO, variable 10 000 - 2500 K
Beam and Aura electronic 'color wheel' effect	33 LEE-referenced colors plus white, variable-speed color-wheel rotation effect and random color
Beam and Aura independent shutter effects	Electronic, with regular and random pulse, burst and strobe effects
Pre-programmed effects	Range of independent and synchronized Beam and Aura FX, two combinable
Electronic dimming	Independent Beam and Aura, four dimming curve options
Zoom	11° - 58° (one-tenth peak angle)
Pan	540°
Tilt	232°
Pan and tilt speed	Adjustable via onboard control panel and DMX

## Optics and Photometric Data

Light source	Osram Ostar high-power long-life emitters
Total luminous output	3850 lumens (zoom at maximum)

## Control and Programming

Control options	Independent or synchronized Beam and Aura control
Control	DMX
RDM	Implemented
Control resolution	.8-bit, with 16-bit control of pan & tilt
DMX channels	14/25
Setting and addressing	Control panel with backlit graphic display
Protocol	USITT DMX512-A, ANSI/ESTA E1.20 RDM
Transceiver	RS-485
Firmware update	Via DMX with Martin USB Duo DMX Interface

## Construction

Color	Black
Housing	High-impact flame-retardant thermoplastic
Protection rating	IP 20

## Installation

Mounting points	M12 hole for rigging clamp, attachment points for surface-mounting bracket
Orientation	Any
Minimum distance to combustible materials	100 mm (3.9 in.) from fixture
Minimum distance to illuminated surfaces	200 mm (7.9 ins.) from fixture
Location	Indoor use only, must be fastened to structure or surface

## Connections

AC power input	Neutrik PowerCon NAC3MPA input socket (blue)
AC power throughput	Neutrik PowerCon NAC3MPB output socket (grey)
DMX data in/out	.5-pin locking XLR

## Electrical

AC power	100-240 V nominal, 50/60 Hz
Maximum total power consumption	.260 W
Power supply unit	Auto-ranging electronic switch mode
Power consumption, all effects static, zero light output	<15 W

## Typical Power and Current

100 V, 60 Hz	236 W, 2.4 A, PF 0.994
120 V, 60 Hz	234 W, 2.0 A, PF 0.992
208 V, 60 Hz	229 W, 1.2 A, PF 0.970
230 V, 50 Hz	228 W, 1.1 A, PF 0.959
240 V, 50 Hz	228 W, 1.0 A, PF 0.953

*PF = power factor. Measurements made at nominal voltage with all LEDs at full intensity. Allow for a deviation of +/- 10%.*

## Thermal

Cooling	Forced air (temperature-regulated, low noise, user-definable levels)
Maximum ambient temperature (Ta max.)	40° C (104° F)
Minimum ambient temperature (Ta min.)	5° C (41° F)
Total heat dissipation (calculated, +/- 10%)	820 BTU/hr.

## Approvals

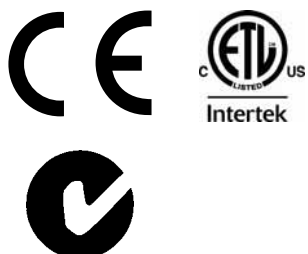

EU safety	EN 60598-2-17 (EN 60598-1), EN 62471
EU EMC	.EN 55103-1, EN 55103-2, EN 55015, EN 61547
US safety	UL 1573
US EMC	FCC Part 15 Class A
Canadian safety	CSA E598-2-17 (CSA E60598-1)
Canadian EMC	ICES-003 Class A
Australia/NZ	C-TICK N4241

## Included Items

M12 bolt suitable for use with Martin rigging clamps	
User manual	P/N 35000254

## Accessories

Set of 5 x quick-mount surface mounting brackets	P/N 91606017
Neutrik PowerCon NAC3FCA power input connector, cable mount, blue	P/N 05342804
Neutrik PowerCon NAC3FCB power output connector, cable mount, light grey	P/N 05342805
G-clamp	P/N 91602003
Half-coupler clamp	P/N 91602005
Quick trigger clamp	P/N 91602007
Safety wire, safe working load 50 kg	P/N 91604003
6-unit flightcase for MAC Aura™	P/N 91515020

## Related Items

Martin USB Duo™ DMX Interface Box	P/N 90703010
-----------------------------------	--------------

## Ordering Information

MAC Aura™ in cardboard box	P/N 90232000
MAC Aura™ in 6-unit flightcase	P/N 90232010

*Specifications subject to change without notice. For the latest product specifications, see [www.martin.com](http://www.martin.com)*

[www.carlosmendoza.com.mx](http://www.carlosmendoza.com.mx)

**Martin**<sup>®</sup>

---

[www.martin.com](http://www.martin.com) • Olof Palmes Allé 18 • 8200 Aarhus N • Denmark  
Tel: +45 8740 0000 • Fax +45 8740 0010